

REVISION HISTORY			
REV	DESCRIPTION	DATE	APPROVED
-	DCN 49553	01/20	BNK

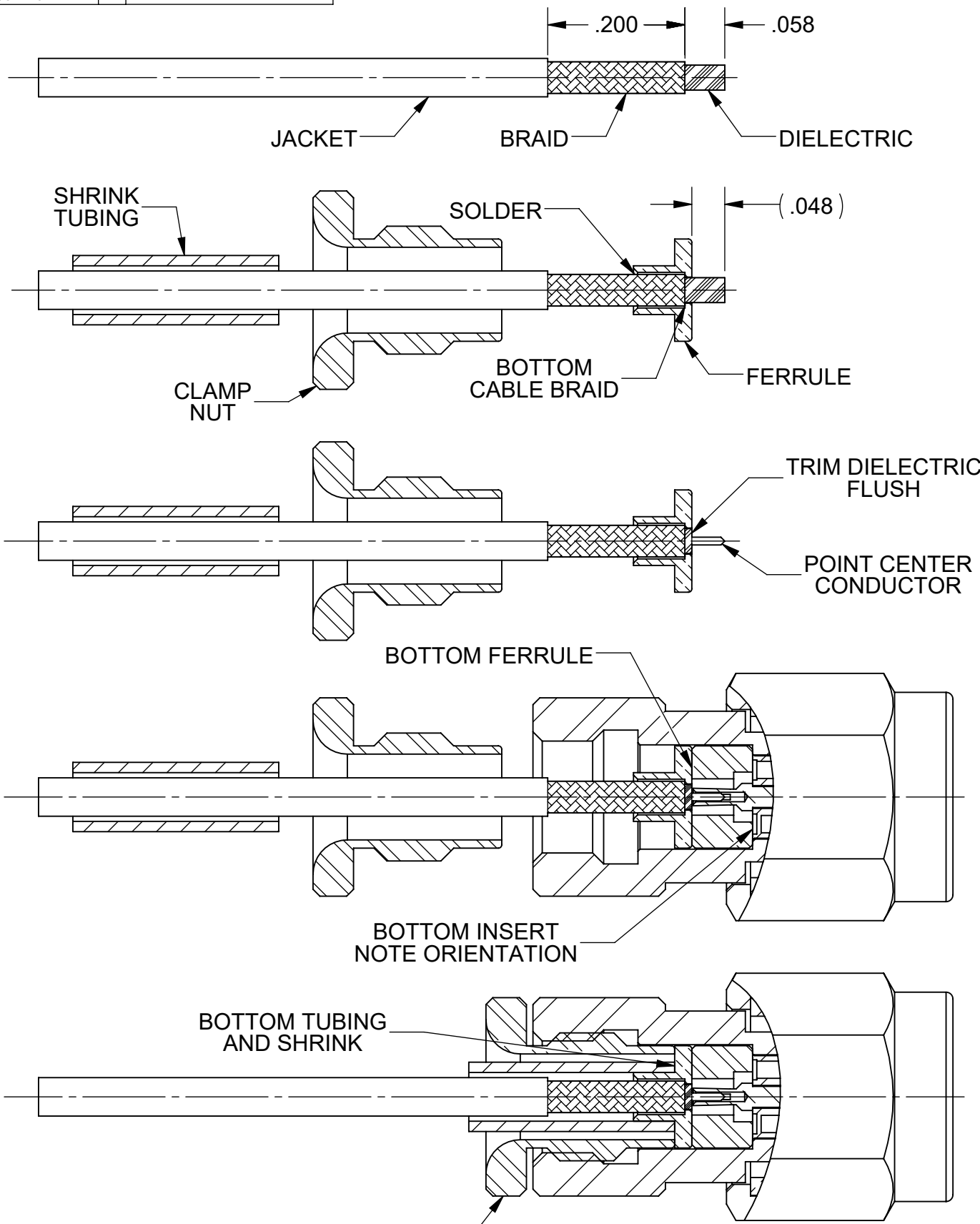

**STEP 1:**  
 1.1) TRIM CABLE JACKET AND BRAID TO DIMENSIONS SHOWN  
 1.2) TIN DIP CABLE UP TO CABLE JACKET

**STEP 2:**  
 2.1) SLIDE SHRINK TUBING AND CLAMP NUT OVER CABLE.  
 2.2) BOTTOM CABLE BRAID ON CABLE STOP INSIDE FERRULE.  
 2.3) SOLDER CABLE BRAID TO FERRULE.

**STEP 3:**  
 3.1) TRIM DIELECTRIC FLUSH WITH FACE OF FERRULE.  
 3.2) POINT CENTER CONDUCTOR.

**STEP 4:**  
 4.1) INSTALL INSERT INTO CONNECTOR BODY. NOTE ORIENTATION.  
 4.2) BOTTOM FERRULE AND CABLE AGAINST INSERT.

**STEP 5:**  
 5.1) TORQUE CLAMP NUT INTO BODY.  
 5.2) BOTTOM SHRINK TUBING AGAINST FERRULE AND SHRINK OVER CABLE.

**NOTES:**  
 1. FOR CONNECTORS WITH DATE CODE EARLIER THAN 08/20 PLEASE CONTACT SALES AT SV MICROWAVE (sales@svmicrowave.com).

TORQUE CLAMP NUT AND BODY

.047 mmWAVE  
 USED ON:

MATERIAL:	N/A
FINISH:	N/A
SURFACE AREA:	N/A
<b>PROPRIETARY</b>	
THE INFORMATION CONTAINED IN THIS DRAWING IS THE SOLE PROPERTY OF SV MICROWAVE, INC. ANY REPRODUCTION IN PART OR AS A WHOLE WITHOUT THE WRITTEN PERMISSION OF SV MICROWAVE, INC IS PROHIBITED.	

DIMENSIONS ARE IN INCHES TOLERANCES:	
FRACTIONAL:	±1/64 ANGULAR: X° ±1°0' X'X' ±15'
DECIMAL:	X ±.030 .XX ±.010 .XXX ±.005
INTERPRET DIMENSIONS AND TOLERANCES PER ASME Y14.5M - 1994	
THIRD ANGLE PROJECTION	

UNLESS OTHERWISE SPECIFIED	
1) ALL DIMENSIONS ARE AFTER PLATING. 2) BREAK CORNERS & EDGES .005 R. MAX. 3) CHAM. 1ST & LAST THREADS. 4) SURFACE ROUGHNESS 63 / MIL-STD-10. 5) DIA.'S ON COMMON CENTERS TO BE CONCENTRIC WITHIN .005 T.I.R. 6) REMOVE ALL BURRS	
DRAWN:	DEF 01/23/20
CHECKED:	BNK 01/23/20
APPROVED:	BNK 01/23/20
E.M. SIMULATION:	N/A



TITLE:		<b>CABLE ASSEMBLY INSTRUCTIONS</b>	
SIZE	DWG. NO.	<b>300-33-009</b>	
<b>B</b>		SCALE: 5:1	SHEET 1 OF 1