

PRODUCT DATA DRAWING

REVISION HISTORY			
REV	DESCRIPTION	DATE	APPROVED
-	NRN 46705	04/22	SEE PDM
A	DCN 51622	05/22	

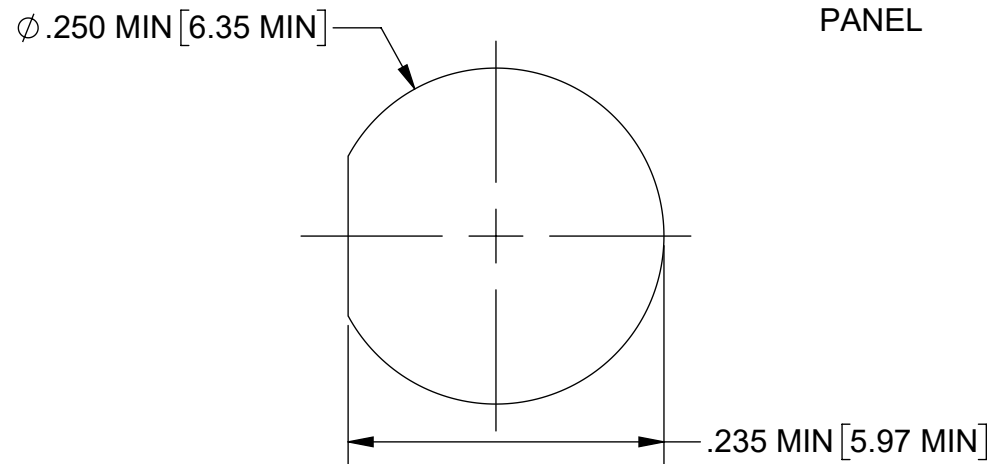
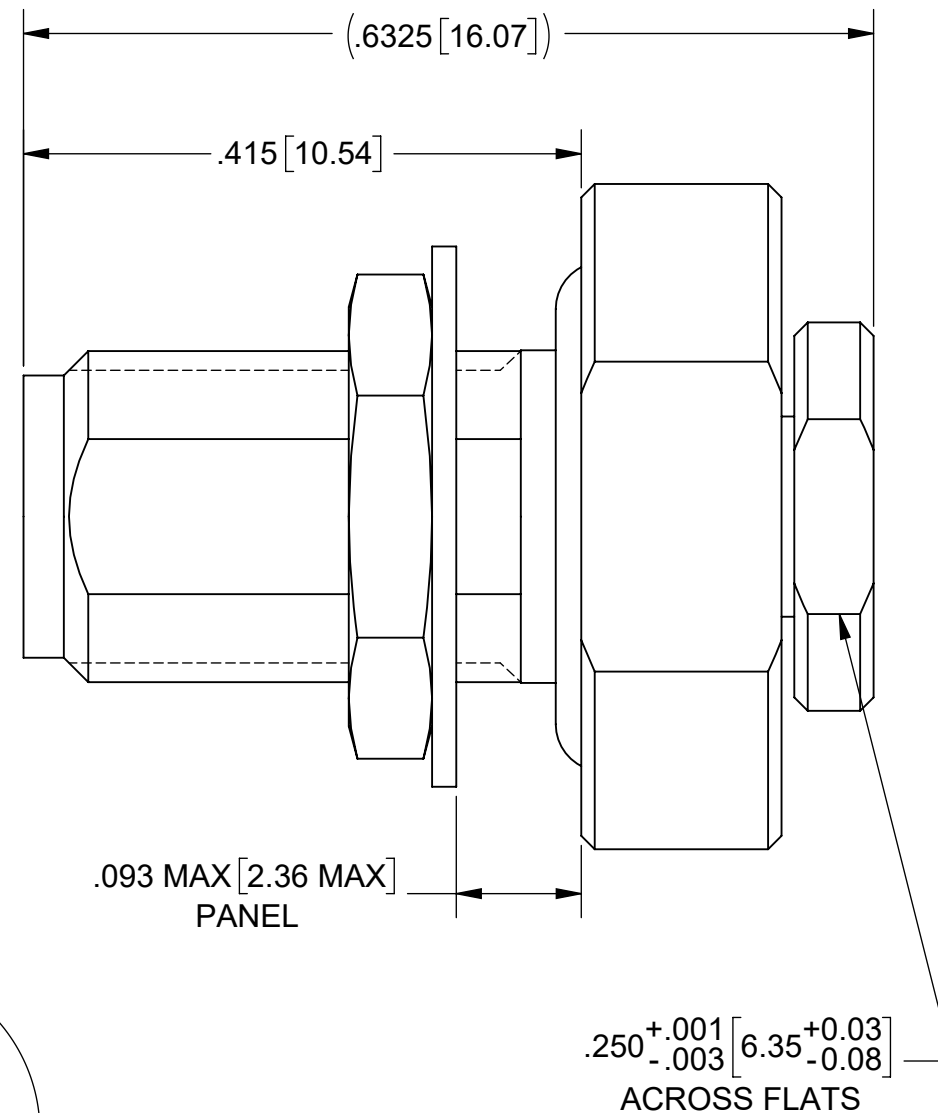
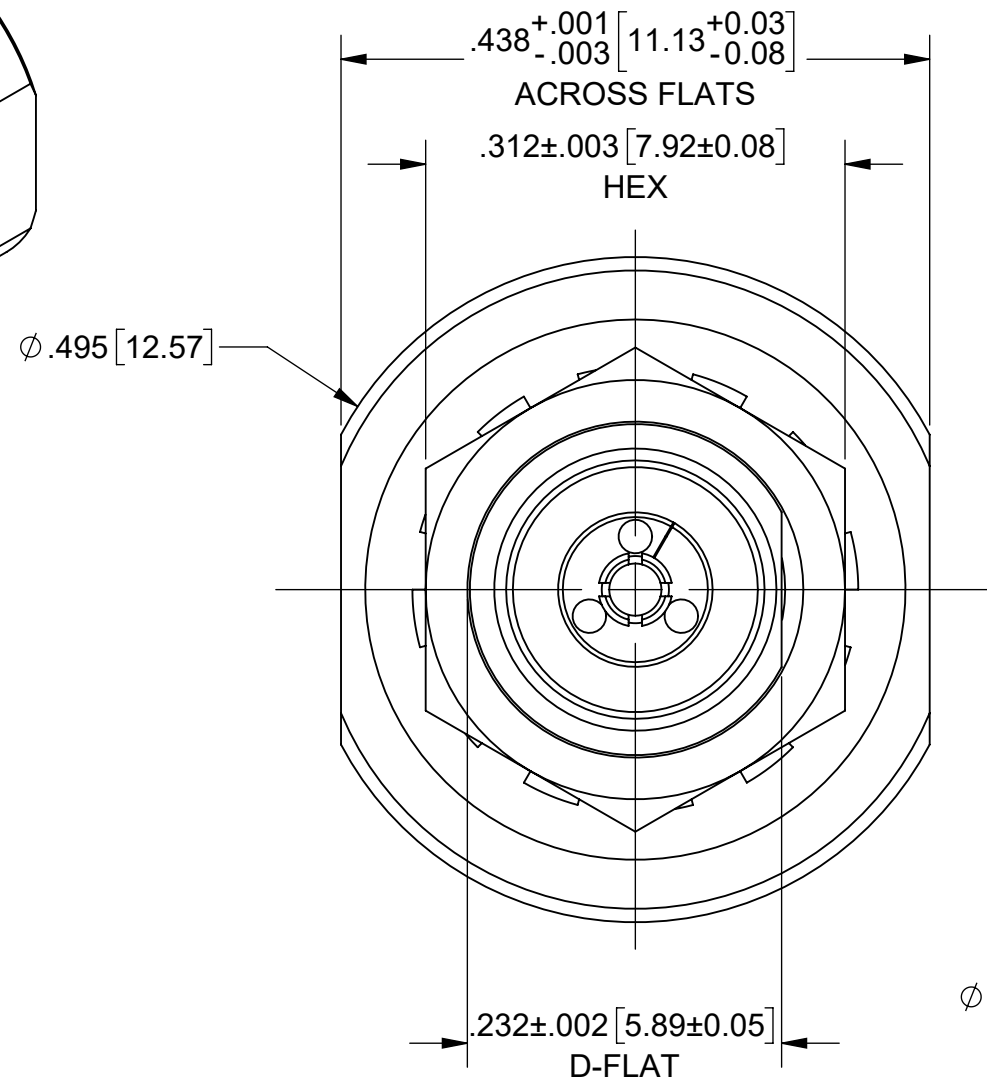
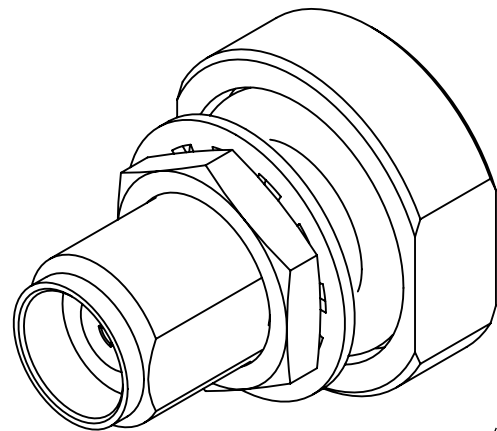

RECOMMENDED MOUNTING HOLE

MATERIAL	
BODY, INSERT, HEX NUT, CLAMP NUT	ALUMINUM
INSULATOR	PTFE
CONTACT, FERRULE	BERYLLIUM COPPER
O-RING	VITON
LOCK WASHER	STAINLESS STEEL

FINISH	
BODY, HEX NUT, CLAMP NUT, CONTACT, FERRULE	GOLD OVER NICKEL
INSERT	CHEMICAL CONVERSION COATING
LOCK WASHER	PASSIVATED

PERFORMANCE	
IMPEDANCE	50 OHMS
FREQ. RANGE	DC TO 40.0 GHZ

MATERIAL:	SEE NOTES
FINISH:	SEE NOTES
SURFACE AREA:	N/A
PROPRIETARY	
<small>THE INFORMATION CONTAINED IN THIS DRAWING IS THE SOLE PROPERTY OF SV MICROWAVE, INC. ANY REPRODUCTION IN PART OR AS A WHOLE WITHOUT THE WRITTEN PERMISSION OF SV MICROWAVE, INC IS PROHIBITED.</small>	

DIMENSIONS ARE IN INCHES TOLERANCES:	
FRACTIONAL:	± 1/64 ANGULAR: X° ± 1°0' X'X' ± 15'
DECIMAL:	X ± .030 .XX ± .010 .XXX ± .005
INTERPRET DIMENSIONS AND TOLERANCES PER ASME Y14.5M - 1994	
THIRD ANGLE PROJECTION	

UNLESS OTHERWISE SPECIFIED	
<small>1) ALL DIMENSIONS ARE IN INCHES (MILLIMETERS) 2) ALL DIMENSIONS ARE AFTER PLATING. 3) BREAK CORNERS & EDGES .005 R. MAX. 4) CHAM. 1ST & LAST THREADS. 5) SURFACE ROUGHNESS 63-MIL-STD-10. 6) DIA: 'S ON COMMON CENTERS TO BE CONCENTRIC WITHIN .005 T.I.R. 7) REMOVE ALL BURRS</small>	
DRAWN:	JPM 04/13/22
CHECKED:	SEE PDM
APPROVED:	SEE PDM

TITLE: 2.9MM STR. F CONNECTOR FOR STANDARD FLEXTRA CABLE	
SIZE	DWG. NO.
B	1521-80001
SCALE: 7:1	SHEET 1 OF 1