

REVISION HISTORY			
REV	DESCRIPTION	DATE	APPROVED
-	NRN 35846	02/10	STW

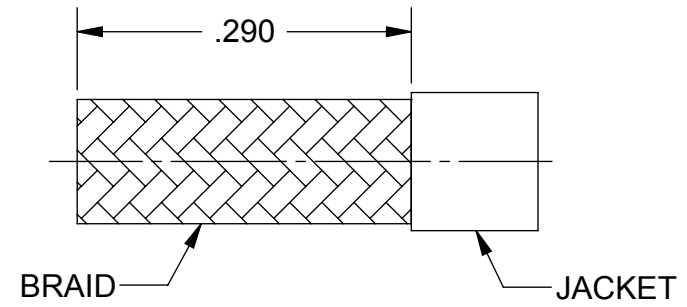

STEP 1:
TRIM JACKET TO DIMENSION SHOWN AND TIN DIP CABLE END.

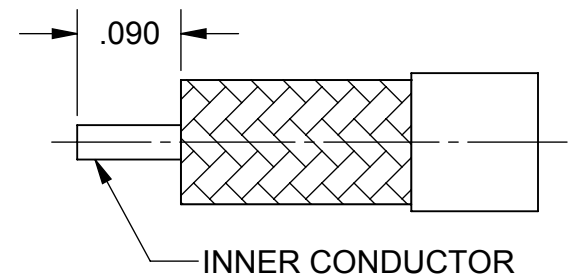

STEP 2:
TRIM CABLE OUTER CONDUCTOR AND DIELECTRIC TO DIMENSION SHOWN.

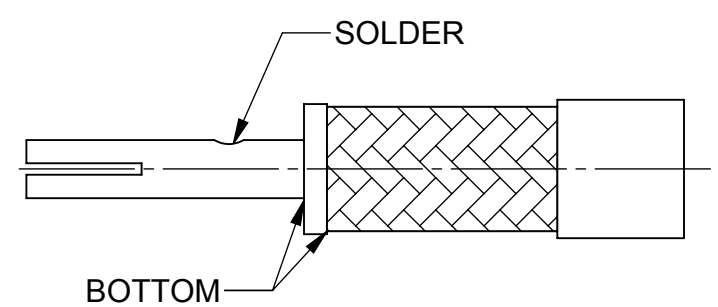

STEP 3:
PLACE INSULATOR AND CONTACT OVER INNER CONDUCTOR AND BOTTOM AS SHOWN. SOFT SOLDER AND REMOVE EXCESS SOLDER IF NECESSARY.

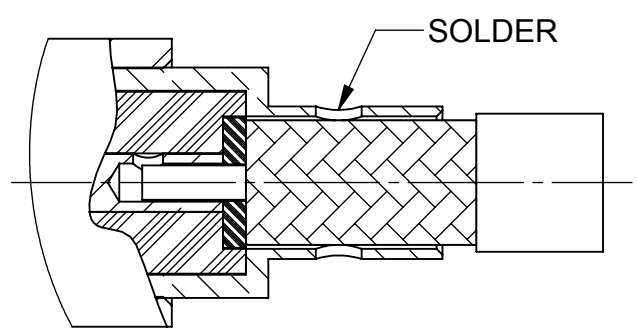

STEP 4:
BOTTOM CABLE SUBASSEMBLY IN BODY AS SHOWN AND SOFT SOLDER.

SF2911-60088
USED ON:

MATERIAL: N/A
FINISH: N/A
SURFACE AREA: N/A
PROPRIETARY
THE INFORMATION CONTAINED IN THIS DRAWING IS THE SOLE PROPERTY OF SV MICROWAVE, INC. ANY REPRODUCTION IN PART OR AS A WHOLE WITHOUT THE WRITTEN PERMISSION OF SV MICROWAVE, INC IS PROHIBITED.

DIMENSIONS ARE IN INCHES TOLERANCES:
FRACTIONAL: ±1/64 ANGULAR: X° ±1'0" X'X' ±15'
DECIMAL: .X ±.030
.XX ±.010
.XXX ±.005
INTERPRET DIMENSIONS AND TOLERANCES PER ASME Y14.5M - 1994
THIRD ANGLE PROJECTION

UNLESS OTHERWISE SPECIFIED
1) ALL DIMENSIONS ARE AFTER PLATING.
2) BREAK CORNERS & EDGES .005 R. MAX.
3) CHAM. 1ST & LAST THREADS.
4) SURFACE ROUGHNESS 63 / MIL-STD-10.
5) DIA.'S ON COMMON CENTERS TO BE CONCENTRIC WITHIN .005 T.I.R.
6) REMOVE ALL BURRS
DRAWN: DAL 02/26/10
CHECKED: STW 02/26/10
APPROVED: STW 02/26/10
E.M. SIMULATION: N/A

SV Microwave, Inc.
2400 Centrepark West Drive, Suite 100
West Palm Beach, FL 33409

TITLE: **CABLE ASSEMBLY INSTRUCTIONS**

SIZE: **B** CAGE CODE: **95077** DWG. NO.: **300-29-091**

SCALE: 6:1 SHEET 1 OF 1