

300-80-445

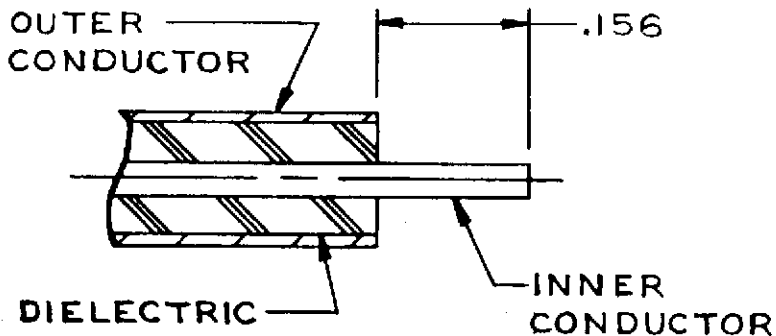

STEP 1

Trim cable outer and inner conductor and dielectric as shown. Do not excessively nick inner conductor.

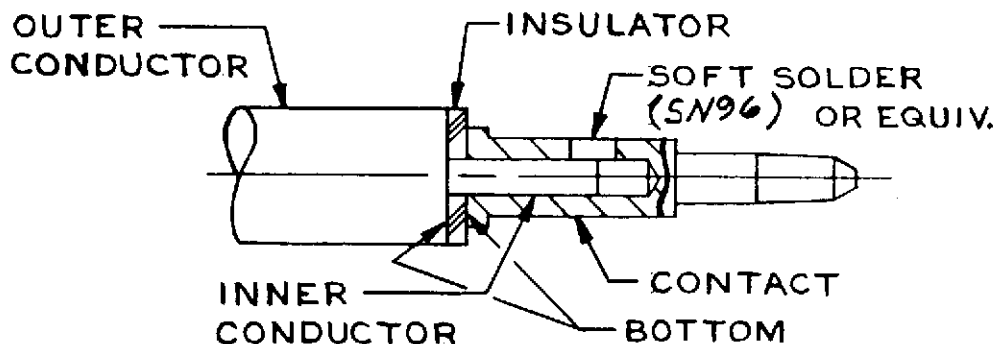

STEP 2

Install insulator and contact over end of cable inner conductor. Solder contact to inner conductor maintaining the bottom condition.

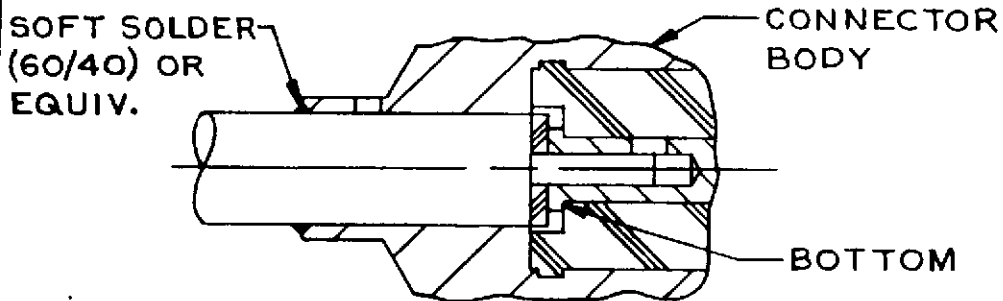

STEP 3

Insert the cable/contact assembly into the connector body until the assembly bottoms. Solder the cable outer conductor to the connector body as shown maintaining the bottom condition.

SYM	DESCRIPTION	DATE	APPR	UNLESS OTHERWISE SPECIFIED
-	REL DCN F-8634	10/81	DGG	1 ALL DIMENSIONS ARE AFTER PLATING
A	REV. DCN. 20062	5/91	RD7	2 BREAK ALL CORNERS & EDGES .005 R MAX
				3 CHAMFER 1ST & LAST THREADS 45°
				4 SURFACE ROUGHNESS 63 MIL STD 10
				5 DIAMETERS ON COMMON CENTERS TO BE CONCENTRIC WITHIN T.I.R.
				6 REMOVE ALL BURRS
				DIMENSIONS ARE IN INCHES TOLERANCES
				DECIMALS FRACTIONAL ANGULAR
				.X ± .030 X' ± 1'0"
				.XX ± .015 ± 1/64 X'X' ± 15'
				.XXX ± .005
				DRAWN <i>WJT</i> DATE 10-26-81
				CHECKED DATE
				APPROVED <i>DGG</i> DATE 10/30/81

SOLITRON/MICROWAVE		REF.
PORT SALERNO, FLORIDA		SF4501-6039
MATERIAL		TITLE
FINISH		CABLE ASSEMBLY INSTRUCTIONS
SCALE	CODE IDENT. NO.	DRAWING NO.
—	95077	300-80-445
SIZE	A	