

SIZE **B** DRAWING NO. **300-80-570**

MADE IN THE U.S.A.

MARK LABEL PER PARTS LIST

Connector Type.....TNC Plug, Cabled,
UG CLAMP ATTACHMENT.
Cable Type.....R- 174, 179, 187, 188 & 316/U
Special Tools.....None

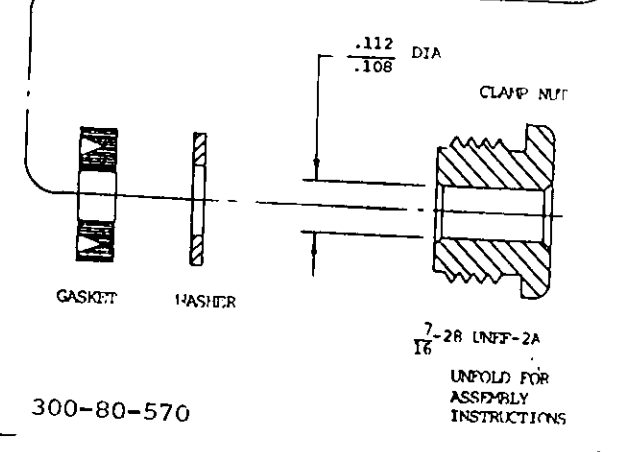
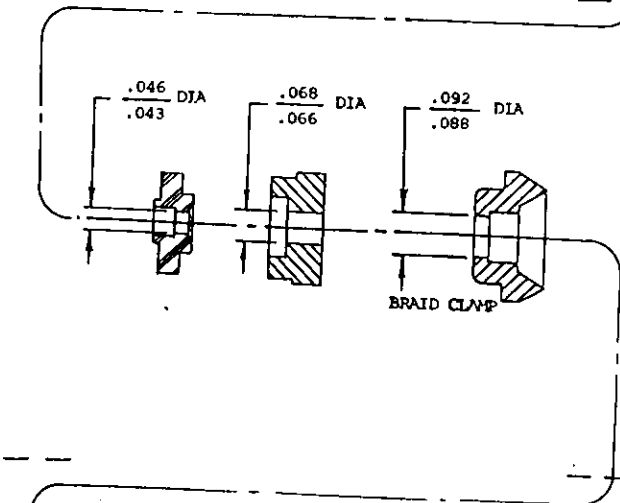
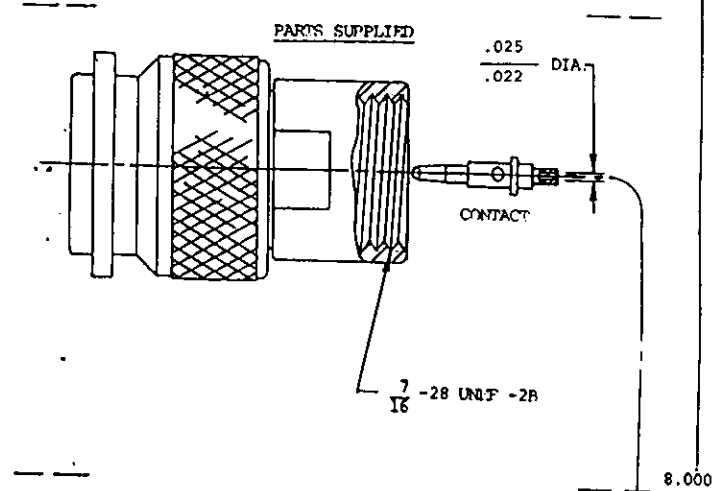

300-80-570

| SY# | DESCRIPTION | DATE | APPR. | ISSUE NO. | NAME OF PART | REF. NO. | PART NO. |
|---|-------------|-------|-------------|---|--------------------|----------|----------|
| 1 | REVISION 1 | 12/85 | (Signature) | | SOLITRON/MICROWAVE | | |
| 1 UNLESS OTHERWISE SPECIFIED 2 ALL DIMENSIONS ARE IN INCHES 3 FRACTIONS SHOULD BE IN DECIMALS 4 ALL DIMENSIONS TO FACE UNLESS NOTED OTHERWISE 5 ALL DIMENSIONS TO CENTER UNLESS NOTED OTHERWISE 6 ALL DIMENSIONS TO THE CENTER OF THE HOLE UNLESS NOTED OTHERWISE 7 ALL DIMENSIONS TO THE CENTER OF THE HOLE UNLESS NOTED OTHERWISE 8 ALL DIMENSIONS TO THE CENTER OF THE HOLE UNLESS NOTED OTHERWISE 9 ALL DIMENSIONS TO THE CENTER OF THE HOLE UNLESS NOTED OTHERWISE | | | | DRAWN R.P.A. DATE 12/85 CHECKED R.P.A. DATE 12/85 APPROVED (Signature) DATE 12/85 | | | |
| SOLITRON/MICROWAVE PORT SALERNO, FLORIDA | | | | TITLE CABLE ASSEMBLY INSTRUCTIONS | | | |
| SCALE 8E6831 | | | | CODE IDENT. NO. B | | | |
| SIZE B | | | | DRAWING NO. 300-80-570 SHEET 1 OF 2 | | | |

ENC. FILE COPY

SIZE B
 DRAWING NO. 300-80-570

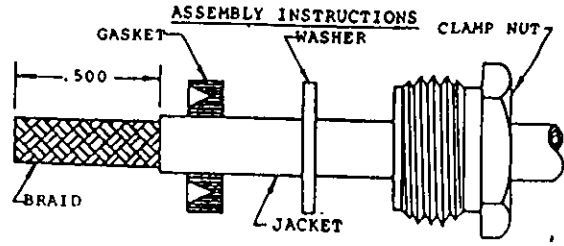

- 1.0 PREPARE CABLE END**
- 1.1 Slide clamp nut, washer and gasket onto cable.
 - 1.2 Trim cable jacket and braid to dimension shown, without nicking braid.

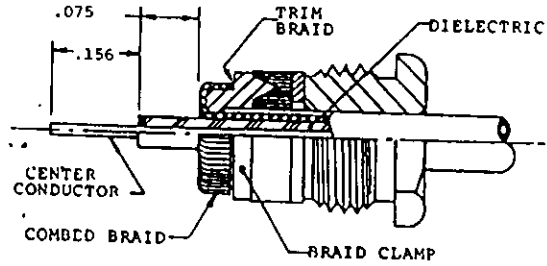

- 2.0 FORM CABLE BRAID OVER CLAMP**
- 2.1 Comb out braid.
 - 2.2 Install clamp and fold braid back over clamp.
 - 2.3 Trim excess braid.
 - 2.4 Trim cable dielectric and center conductor to dimensions shown.
 - 2.5 Tin center conductor.

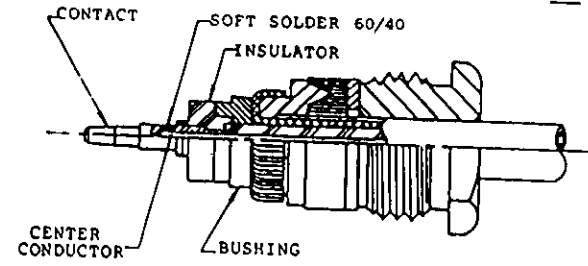

- 3.0 SOLDER CONTACT**
- 3.1 Install bushing, insulator and contact bottoming each.
 - 3.2 Soft solder contact to center conductor.
 - 3.3 Remove excess solder.

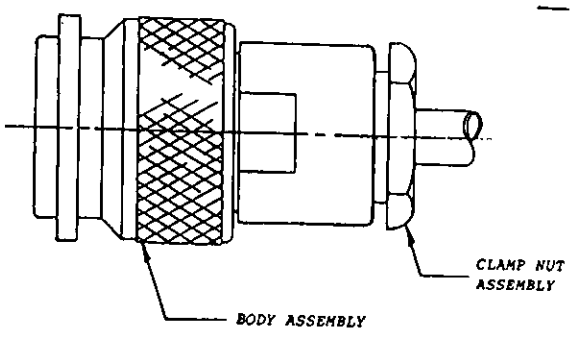

- 4.0 INSTALL CLAMP NUT ASSY INTO BODY ASSY.**
- 4.1 Thread clamp nut assembly into body assembly and wrench tighten to recommended torque 25-30 inch lbs.

| SVM | DESCRIPTION | DATE | APP. NO. | UNLESS OTHERWISE SPECIFIED |
|--|------------------|------------------------|--------------------|---|
| | REL. DCA F-10232 | 12/85 | | 1. ALL DIMENSIONS ARE IN INCHES 2. DIMENSIONS WITH DECIMALS ARE TO BE PLACE DECIMALS 3. REMOVE ALL BURRS & SHARP EDGES 4. CHAMFER 1ST & LAST THREADS 45° 5. ALL DIMENSIONS TO BE CONCERNING 6. SURFACE ROUGHNESS |
| DRAWN Z.P.A. DATE 11/24/85 | | | | 1-288 2-216 |
| CHECKED E.P.A. DATE 12-85 | | | | |
| APPROVED [Signature] DATE 2/10-85 | | | | |
| MATERIAL SOLITRON/MICROWAVE PORT SALERNO, FLORIDA | | SCALE 1-1 | CODICENT NO. 95077 | |
| FINISH | | SIZE B | | |
| TITLE CABLE ASSEMBLY INSTRUCTIONS | | DRAWING NO. 300-80-570 | SHEET 2 OF 2 | |

8.000

ENG. FILE COPY