

PRODUCT DATA DRAWING

REVISION HISTORY			
REV	DESCRIPTION	DATE	APPROVED
-	NRN 42309	06/18	STW
A	DCN 49999	07/20	STW
B	DCN 50305	11/20	ELA

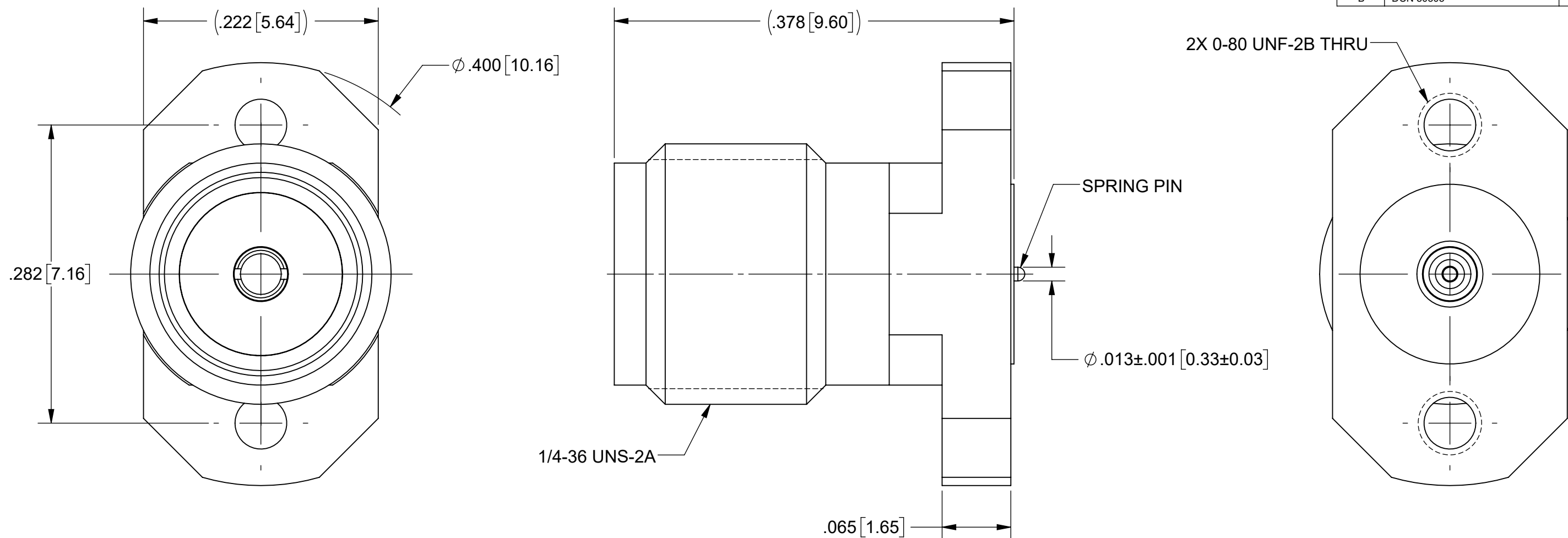

MATERIAL:

BODY: STAINLESS STEEL PER AMS-5640, ALLOY UNS S30300, TYPE 1; OR ASTM A582 TYPE 303, COND. A

CONTACTS: BERYLLIUM COPPER PER ASTM B196, ALLOY No. UNS C17300, TD04

INSULATOR: PTFE PER ASTM D1710, TYPE I, GRADE 1, CLASS B

FINISH:

BODY: PASSIVATED PER AMS-2700

CONTACTS: GOLD PER ASTM B488, TYPE II, CODE C, CLASS 1.27, OVER NICKEL PER AMS-QQ-N-290, CLASS 1, .00005" MIN.

PERFORMANCE:

IMPEDANCE: 50 OHMS
FREQ. RANGE: DC TO 26.5 GHz

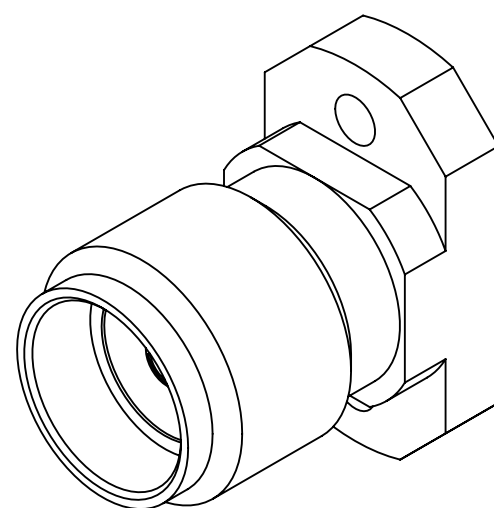

SV P/N	DESCRIPTION	PCB THICKNESS
SF2921-61507	NO SCREWS	.005 TO .373
SF2921-61507-1S	INCL. TWO .188 SCREWS	.053 TO .123

NOTES:

- FOR RECOMMENDED FOOTPRINT FOR YOUR PCB, CONTACT SV MICROWAVE SALES DEPARTMENT (sales@svmicro.com, 561-840-1800).

MATERIAL: SEE NOTES	DIMENSIONS ARE IN INCHES TOLERANCES: FRACTIONAL: $\pm 1/64$ ANGULAR: X° $\pm 1'0''$ X'X' $\pm 15'$	UNLESS OTHERWISE SPECIFIED 1) ALL DIMENSIONS ARE IN INCHES (MILLIMETERS) 2) ALL DIMENSIONS ARE AFTER PLATING. 3) BREAK CORNERS & EDGES .005 R. MAX. 4) CHAM. 1ST & LAST THREADS. 5) SURFACE ROUGHNESS 63-MIL-STD-10. 6) DIA: 'S ON COMMON CENTERS TO BE CONCENTRIC WITHIN .005 T.I.R. 7) REMOVE ALL BURRS	 www.svmicrowave.com TITLE: SMA FEMALE 2 HOLE FLANGE MOUNT W/ SPRING PIN FOR STRIPLINE SIZE DWG. NO. B SF2921-61507-XS SCALE: 10:1 SHEET 1 OF 1
FINISH: SEE NOTES	DECIMAL: X $\pm .030$.XX $\pm .010$.XXX $\pm .005$	INTERPRET DIMENSIONS AND TOLERANCES PER ASME Y14.5M - 1994	
SURFACE AREA: N/A	THIRD ANGLE PROJECTION	DRAWN: JDT 06/05/18 CHECKED: STW 06/06/18 APPROVED: STW 06/06/18	
<p>PROPRIETARY</p> <p>THE INFORMATION CONTAINED IN THIS DRAWING IS THE SOLE PROPERTY OF SV MICROWAVE, INC. ANY REPRODUCTION IN PART OR AS A WHOLE WITHOUT THE WRITTEN PERMISSION OF SV MICROWAVE, INC IS PROHIBITED.</p>			