

PRODUCT DATA DRAWING

REVISION HISTORY			
REV	DESCRIPTION	DATE	APPROVED
-	NRN 48121	3/24	SEE PDM

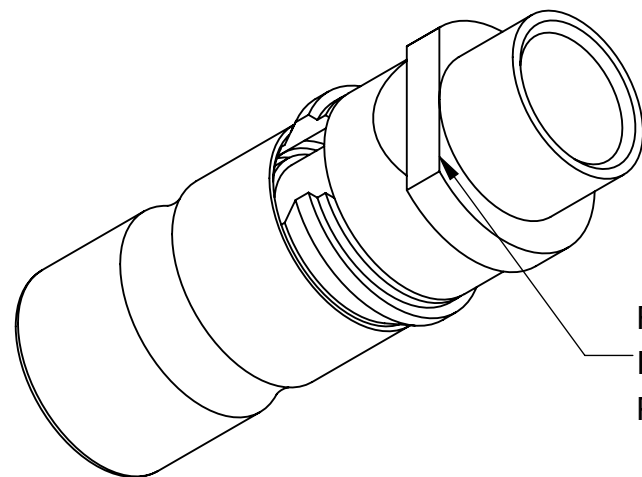

FLAT PREVENTS INTERFERENCE IN SOME PORTS OF PLUG-IN MODULE

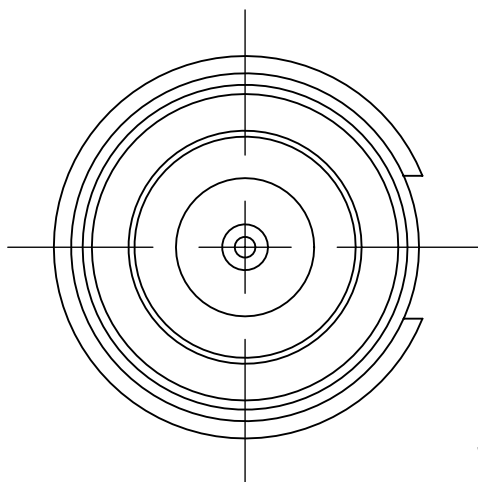

75 OHM SMPM SMOOTH BORE

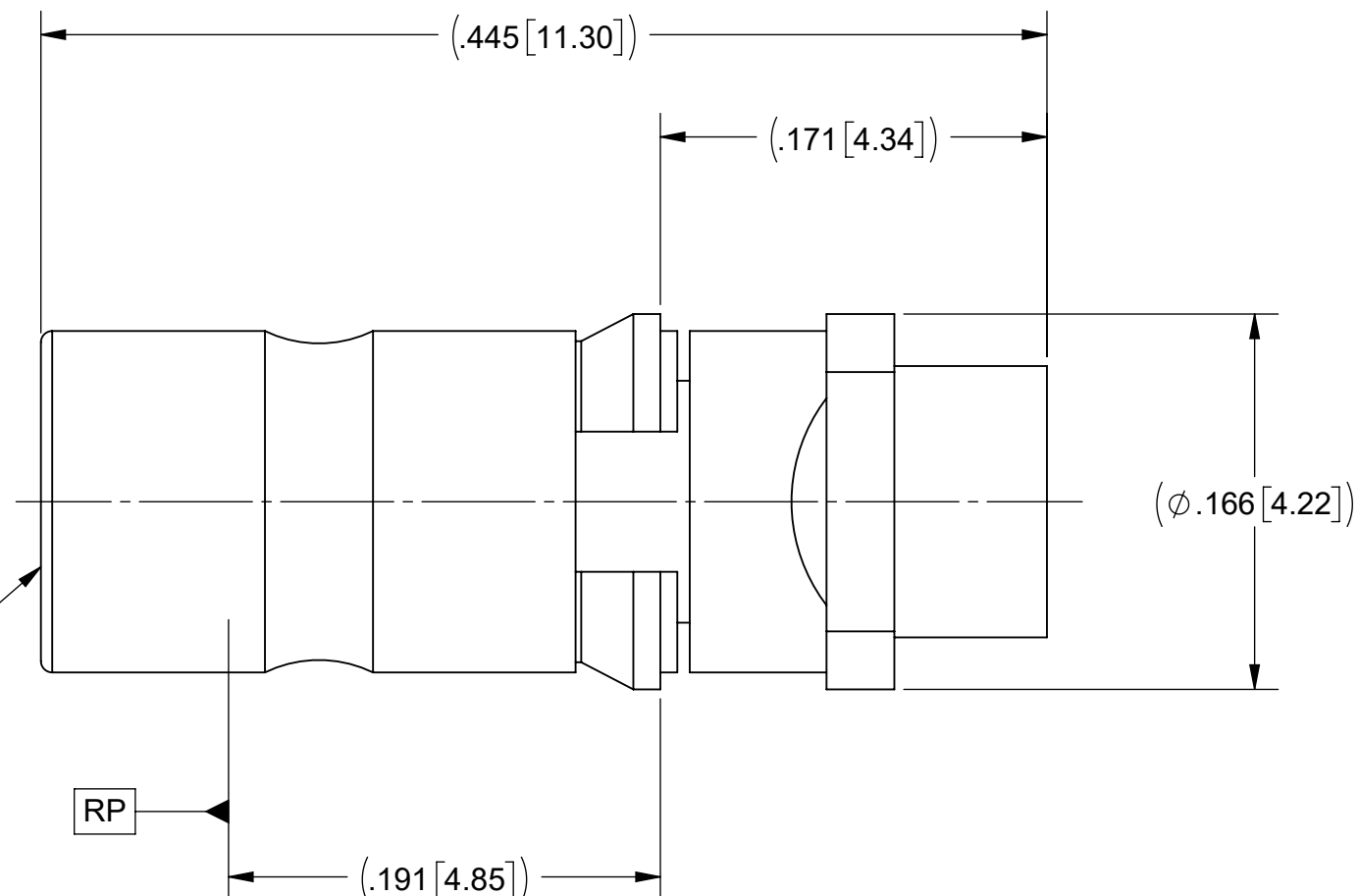

MATERIAL:

BODY & SHROUD: STAINLESS STEEL PER AMS-5640, ALLOY UNS S30300, TYPE 1; OR ASTM A582 TYPE 303, COND. A

RETAINING RING & CONTACT: BERYLLIUM COPPER PER ASTM B196, ALLOY No. UNS C17300, TD04

INSULATOR: PTFE PER ASTM D1710, TYPE I, GRADE 1, CLASS B

FINISH:

SHROUD: PASSIVATED PER AMS-2700

BODY & CONTACT: GOLD PER ASTM B488, TYPE II, CODE C, CLASS 1.27, OVER NICKEL PER AMS-QQ-N-290, CLASS 1, .00005" MIN.

RETAINING RING: NICKEL PER AMS-QQ-N-290, CLASS 1, GRADE G

PERFORMANCE:

IMPEDANCE: 75 OHMS
FREQ. RANGE: DC TO 18.0 GHz

NOTES:

- FOR USE IN ALL PORT LOCATIONS OF 9311-60220, 9311-60221, OR SIMILAR PLUG-IN MODULES.
- WILL FIT INTO, BUT NOT RECOMMENDED FOR USE WITH, SF9311-60097, SF9311-60147, OR SIMILAR PLUG-IN MODULES. FRONT PLATE OF THESE MODULES WILL NOT SUFFICIENTLY HOLD THIS CONTACT RADIALLY.
- MATES TO CONTACT 7521-40001 OR SIMILAR.
- RECOMMENDED REMOVAL TOOL: 500-32-044.

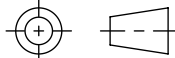
MATERIAL: SEE NOTES	DIMENSIONS ARE IN INCHES TOLERANCES: FRACTIONAL: $\pm 1/64$ ANGULAR: X° $\pm 1'0''$ X°X' $\pm 15''$	UNLESS OTHERWISE SPECIFIED 1) ALL DIMENSIONS ARE IN INCHES (MILLIMETERS) 2) ALL DIMENSIONS ARE AFTER PLATING. 3) BREAK CORNERS & EDGES .005 R. MAX. 4) CHAM. 1ST & LAST THREADS. 5) SURFACE ROUGHNESS 63-MIL-STD-10. 6) DIA: 'S ON COMMON CENTERS TO BE CONCENTRIC WITHIN .005 T.I.R. 7) REMOVE ALL BURRS	 TITLE: 75 OHM STR SMPM M (SB) VITA 67.3 PLUG-IN CONNECTOR FOR BELDEN 1672A CABLE
FINISH: SEE NOTES	DECIMAL: X $\pm .030$.XX $\pm .010$.XXX $\pm .005$	INTERPRET DIMENSIONS AND TOLERANCES PER ASME Y14.5M - 1994	
SURFACE AREA: N/A	THIRD ANGLE PROJECTION	DRAWN: SSR 3/4/24	SIZE DWG. NO. B 7511-60002
PROPRIETARY THE INFORMATION CONTAINED IN THIS DRAWING IS THE SOLE PROPERTY OF SV MICROWAVE, INC. ANY REPRODUCTION IN PART OR AS A WHOLE WITHOUT THE WRITTEN PERMISSION OF SV MICROWAVE, INC IS PROHIBITED.		CHECKED: SEE PDM	SCALE: 12:1
		APPROVED: SEE PDM	SHEET 1 OF 1