

# PRODUCT DATA DRAWING

REVISION HISTORY			
REV	DESCRIPTION	DATE	APPROVED
E	DCN 55095	08/26	SEE PDM

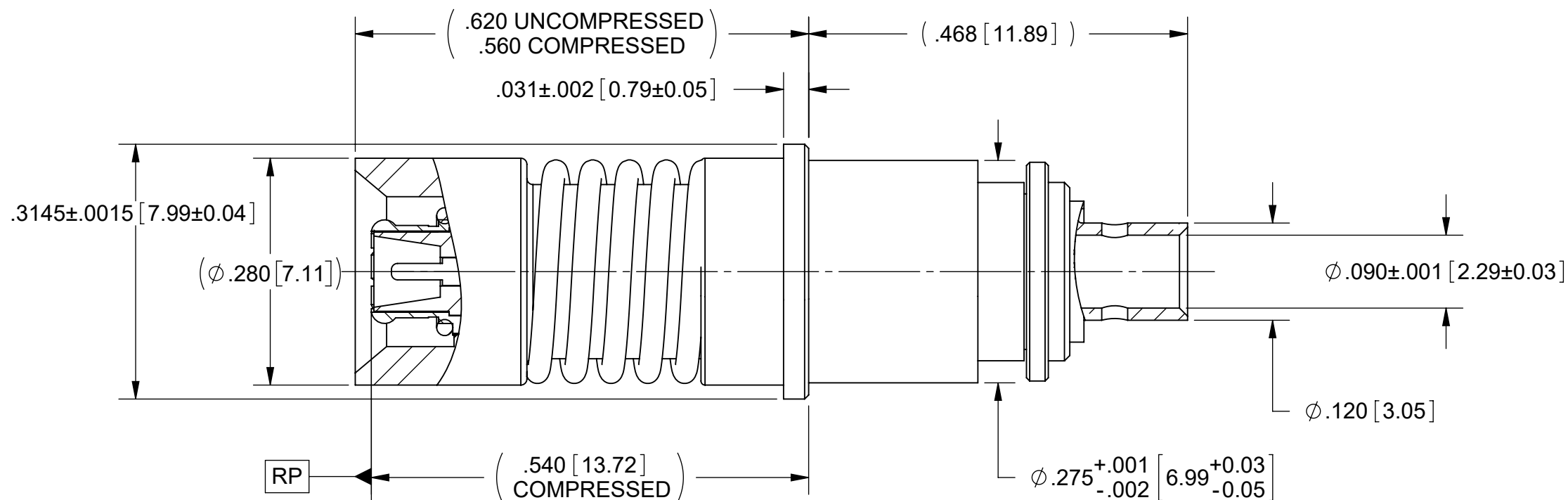

## MATERIAL:

**BODY & SLEEVE:** STAINLESS STEEL PER AMS 5640, ALLOY UNS S30300, TYPE 1 OR ASTM A582, TYPE 303, CONDITION A.

**FERRULE:** BRASS PER ASTM B16 ALLOY UNS No. 36000.

**CONTACT & LOCK RING:** BERYLLIUM COPPER PER ASTM B196, ALLOY No. UNS C17300, TD04.

**INSULATOR:** PTFE PER ASTM D1710, TYPE I, GRADE 1, CLASS B.

**GASKET:** SILICONE RUBBER PER A-A-59588, CLASS 2B, GRADE 60/70.

**SPRING:** STAINLESS STEEL TYPE 302.

## FINISH:

**BODY, SLEEVE & SPRING:** PASSIVATED PER AMS 2700.

**CONTACT & FERRULE:** GOLD PER ASTM B488, TYPE II, CODE C, CLASS 1.27 OVER NICKEL PER AMS-QQ-N-290, CLASS 1, .00005" MIN.

**LOCK RING:** NICKEL PER AMS-QQ-N-290.

## PERFORMANCE:

**IMPEDANCE:** 50 OHMS

**FREQ. RANGE:** DC TO 40.0 GHz

**VSWR:** 1.40:1 MAX. MATED PAIR DC TO 40.0 GHz

**INSERTION LOSS:** .06 X SQRT(F IN GHz)

**DWV:** 1000 VRMS

**OPERATING TEMP.:** -55 °C TO +125 °C

## NOTES:

- ALL SOCKET CONTACTS DESIGNED FOR SERIES I, III OR IV.
- MATES TO SF9921-6000 SOCKET AND SIMILAR, NON-STANDARD BMZ INTERFACE.

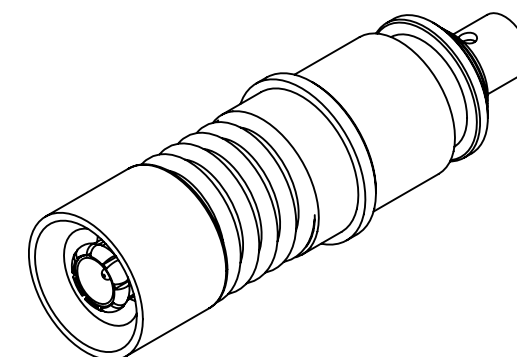

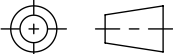
MATERIAL: SEE NOTES	DIMENSIONS ARE IN INCHES TOLERANCES: FRACTIONAL: ±1/64 ANGULAR: X° ±1'0" X'X' ±15'	UNLESS OTHERWISE SPECIFIED 1) ALL DIMENSIONS ARE IN INCHES (MILLIMETERS) 2) ALL DIMENSIONS ARE AFTER PLATING. 3) BREAK CORNERS & EDGES .005 R. MAX. 4) CHAM. 1ST & LAST THREADS. 5) SURFACE ROUGHNESS 63-MIL-STD-10. 6) DIA: 'S ON COMMON CENTERS TO BE CONCENTRIC WITHIN .005 T.I.R. 7) REMOVE ALL BURRS	 www.svmicrowave.com <b>TITLE: 40 GHz SIZE 8/BMZ(S) SOCKET TO TFLEX405 FOR D38999 CONNECTOR</b> SIZE DWG. NO. <b>B SF9911-6000</b>
FINISH: SEE NOTES	DECIMAL: X ±.030 .XX ±.010 .XXX ±.005	INTERPRET DIMENSIONS AND TOLERANCES PER ASME Y14.5M - 1994	
SURFACE AREA: N/A	THIRD ANGLE PROJECTION	DRAWN: JMC 10/24/07	SCALE: 6:1
<b>PROPRIETARY</b> THE INFORMATION CONTAINED IN THIS DRAWING IS THE SOLE PROPERTY OF SV MICROWAVE, INC. ANY REPRODUCTION IN PART OR AS A WHOLE WITHOUT THE WRITTEN PERMISSION OF SV MICROWAVE, INC IS PROHIBITED.		CHECKED: SEE PDM	SHEET 1 OF 1
		APPROVED: SEE PDM	