

REVISION HISTORY			
REV	DESCRIPTION	DATE	APPROVED
-	NRN 48661	10/24	SEE PDM

# PRODUCT DATA DRAWING

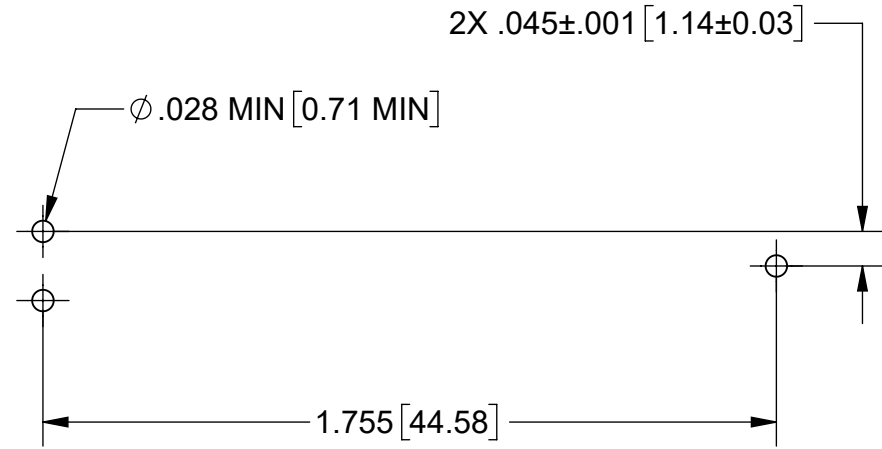

**RECOMMENDED MOUNTING HOLE PATTERN**

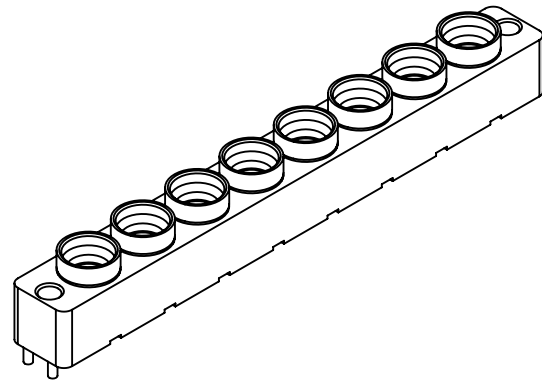
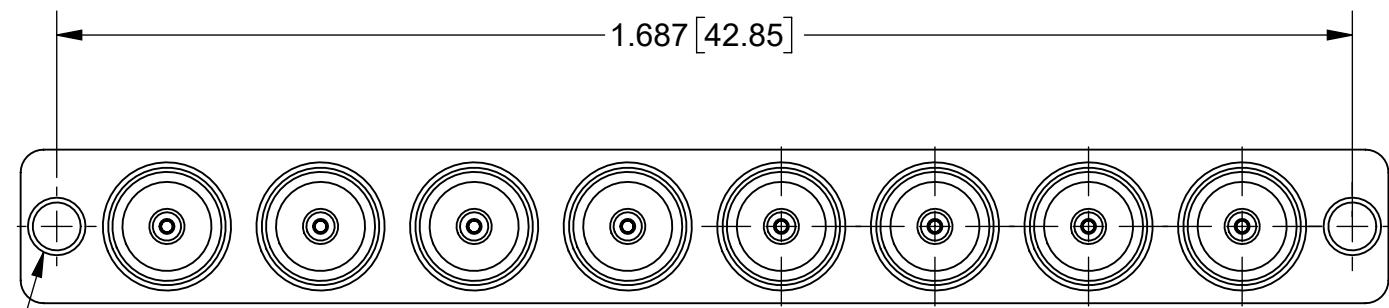
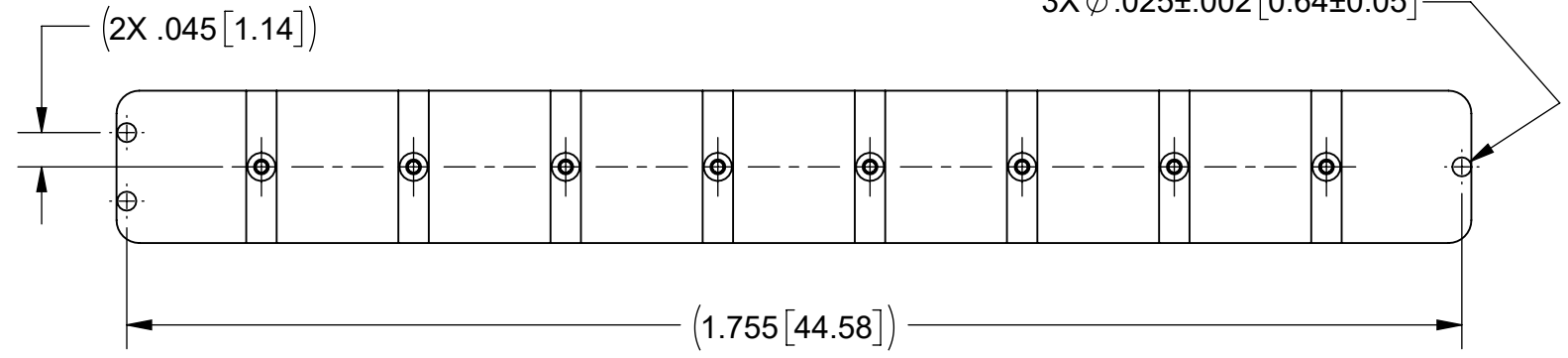
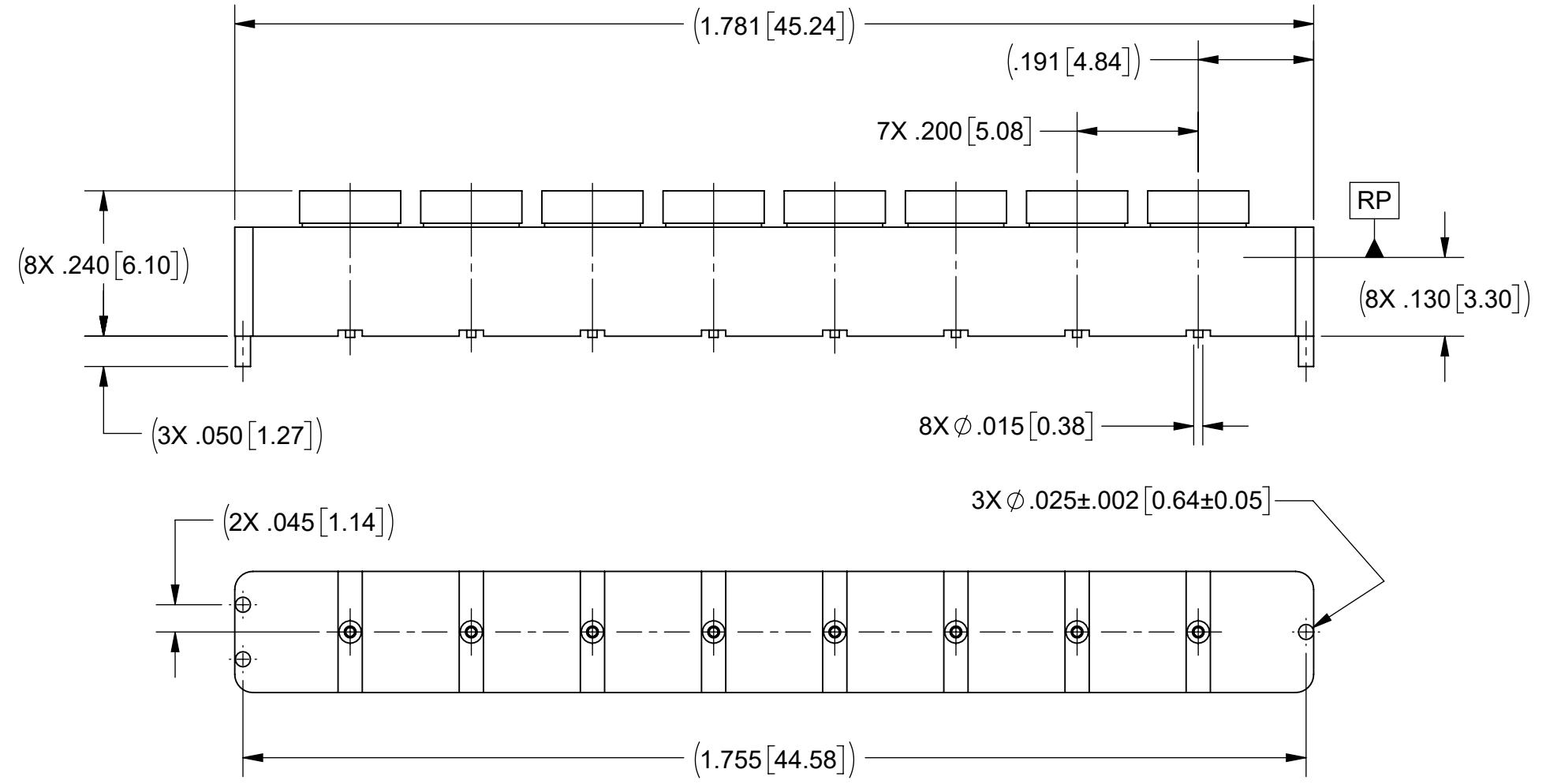

2X ACCEPTS Ø.0625  
ALIGNMENT PIN  
MAX DEPTH OF .095

**ALIGNMENT PIN INFORMATION**

**MATERIAL:**

BODY & SHROUDS: BRASS PER ASTM B16, ALLOY UNS No. C36000

CONTACTS: BERYLLIUM COPPER PER ASTM B196, ALLOY No. UNS C17300, TD04

INSULATORS: ULTEM 1000

**FINISH:**

BODY, SHROUDS, & CONTACTS: GOLD PER ASTM B488, TYPE II, CODE C, CLASS 1.27, OVER NICKEL PER AMS-QQ-N-290, CLASS 1, .00005" MIN.

**PERFORMANCE:**

IMPEDANCE: 50 OHMS  
FREQ. RANGE: DC TO 40.0 GHz.

NOTES:  
1. FOR RECOMMENDED FOOTPRINT TO YOUR SPECIFIC PCB, PLEASE CONTACT SV MICROWAVE AT applications@svmicro.com.

MATERIAL: SEE NOTES	DIMENSIONS ARE IN INCHES TOLERANCES: FRACTIONAL: ±1/64 ANGULAR: X° ±1°0' X'X' ±15'	UNLESS OTHERWISE SPECIFIED 1) ALL DIMENSIONS ARE IN INCHES (MILLIMETERS) 2) ALL DIMENSIONS ARE AFTER PLATING. 3) BREAK CORNERS & EDGES .005 R. MAX. 4) CHAM. 1ST & LAST THREADS. 5) SURFACE ROUGHNESS 63-MIL-STD-10. 6) DIA: 'S ON COMMON CENTERS TO BE CONCENTRIC WITHIN .005 T.I.R. 7) REMOVE ALL BURRS	 www.svmicrowave.com TITLE: <b>SMP FD MALE 8-PORT SURFACE MOUNT</b> SIZE DWG. NO. <b>B 9311-00070</b> SCALE: 4:1 SHEET 1 OF 1
FINISH: SEE NOTES	DECIMAL: X ±.030 .XX ±.010 .XXX ±.005	INTERPRET DIMENSIONS AND TOLERANCES PER ASME Y14.5M - 1994	
SURFACE AREA: N/A	THIRD ANGLE PROJECTION	DRAWN: KRR 10/09/24 CHECKED: SEE PDM APPROVED: SEE PDM	

**PROPRIETARY**  
THE INFORMATION CONTAINED IN THIS DRAWING IS THE SOLE PROPERTY OF SV MICROWAVE, INC. ANY REPRODUCTION IN PART OR AS A WHOLE WITHOUT THE WRITTEN PERMISSION OF SV MICROWAVE, INC IS PROHIBITED.