

REVISION HISTORY			
REV	DESCRIPTION	DATE	APPROVED
-	NRN 34620	02/08	JMC

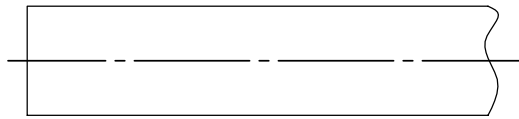

STEP 1

FLUSH CUT END OF CABLE BEFORE REMOVING THE FEP JACKET. DIP END OF THE CABLE INTO FLUX AND THEN INTO A SOLDER POT MAINTAINED AT 500 °F TO A DEPTH OF 3/8" FOR (6) SECONDS MAX.

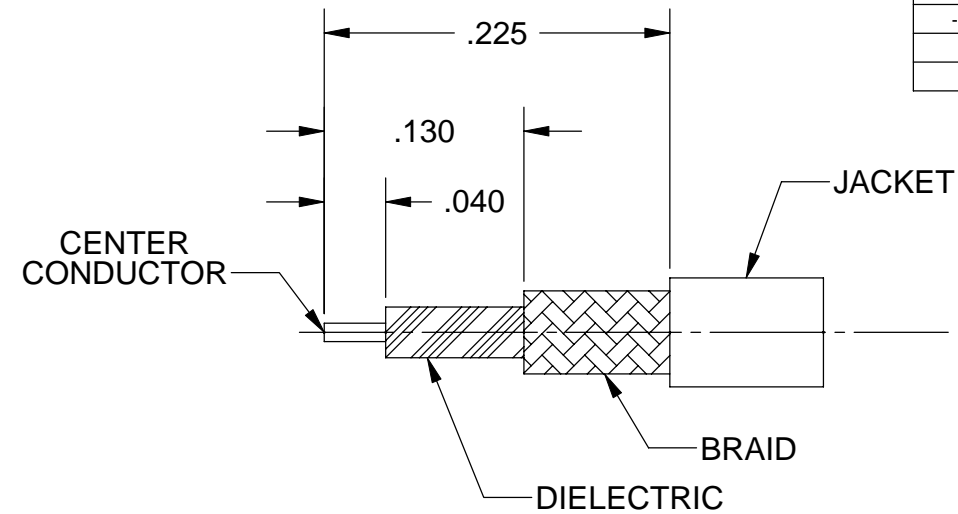

STEP 2

AFTER PRE TINNING TRIM TO DIMENSIONS SHOWN

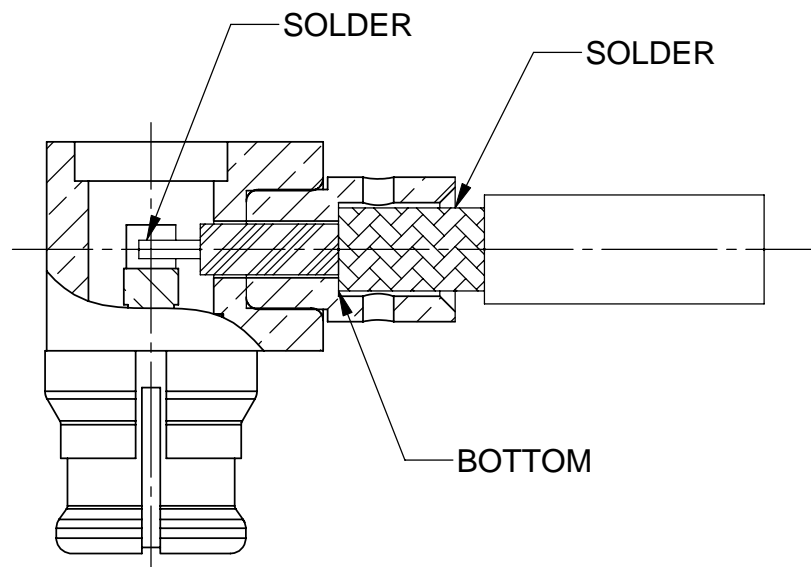

STEP 3

INSTALL CABLE INTO BODY AND SOFT SOLDER CABLE TO BODY AS SHOWN

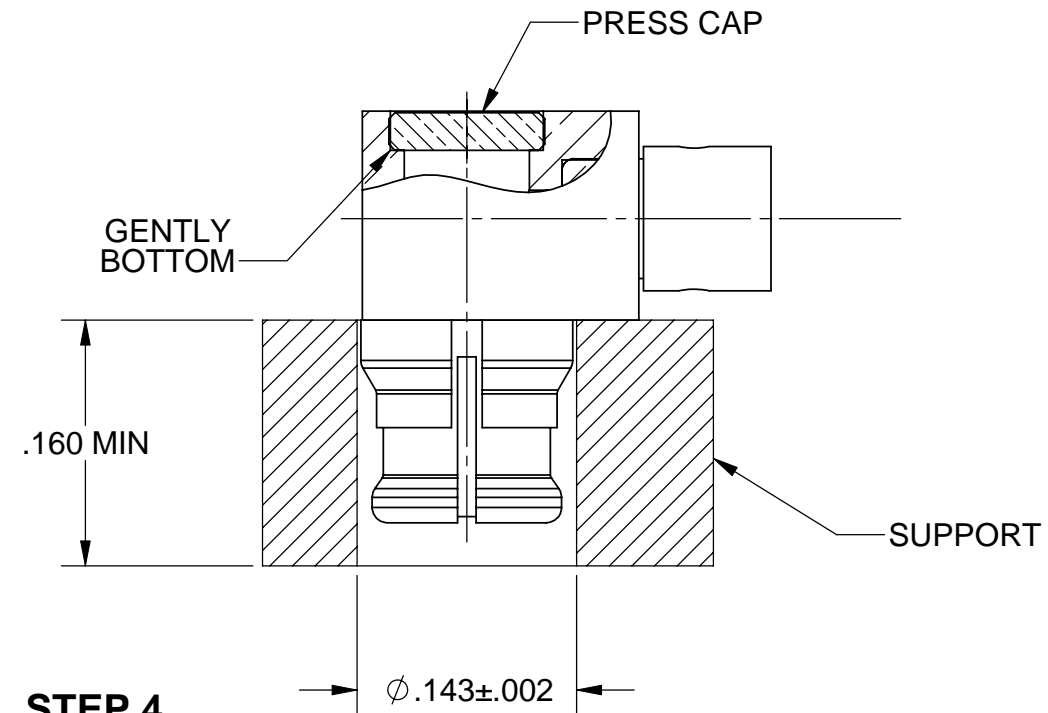

STEP 4

INSTALL PRESS CAP UNTIL SEATED

MATERIAL: N/A	DIMENSIONS ARE IN INCHES TOLERANCES: FRACTIONAL: $\pm 1/64$ ANGULAR: X° $\pm 1^{\circ}0'$ DECIMAL: X $\pm .030$.XX $\pm .010$.XXX $\pm .005$	UNLESS OTHERWISE SPECIFIED 1) ALL DIMENSIONS ARE AFTER PLATING. 2) BREAK CORNERS & EDGES .005 R. MAX. 3) CHAM. 1ST & LAST THREADS. 4) SURFACE ROUGHNESS 63 $\sqrt{\text{MIL-STD-10}}$. 5) DIA.'S ON COMMON CENTERS TO BE CONCENTRIC WITHIN T.I.R. 6) REMOVE ALL BURRS	SV Microwave, Inc. 2400 Centrepark West Drive, Suite 100 West Palm Beach, FL 33409 TITLE: CABLE ASSEMBLY INSTRUCTIONS
FINISH: N/A	INTERPRET DIMENSIONS AND TOLERANCES PER ASME Y14.5M - 1994	DRAWN: STW 02/24/08	
SURFACE AREA: N/A	THIRD ANGLE PROJECTION	CHECKED: JMC 02/25/08	SIZE B CAGE CODE 95077 DWG. NO. 300-12-022
PROPRIETARY THE INFORMATION CONTAINED IN THIS DRAWING IS THE SOLE PROPERTY OF SV MICROWAVE, INC. ANY REPRODUCTION IN PART OR AS A WHOLE WITHOUT THE WRITTEN PERMISSION OF SV MICROWAVE, INC IS PROHIBITED.		APPROVED: JMC 02/25/08	SCALE: 1:1
1222-4006		E.M. SIMULATION: N/A	SHEET 1 OF 1
USED ON:			