

PRODUCT DATA DRAWING

REVISION HISTORY			
REV	DESCRIPTION	DATE	APPROVED
B	DCN 41831	10/15	STW

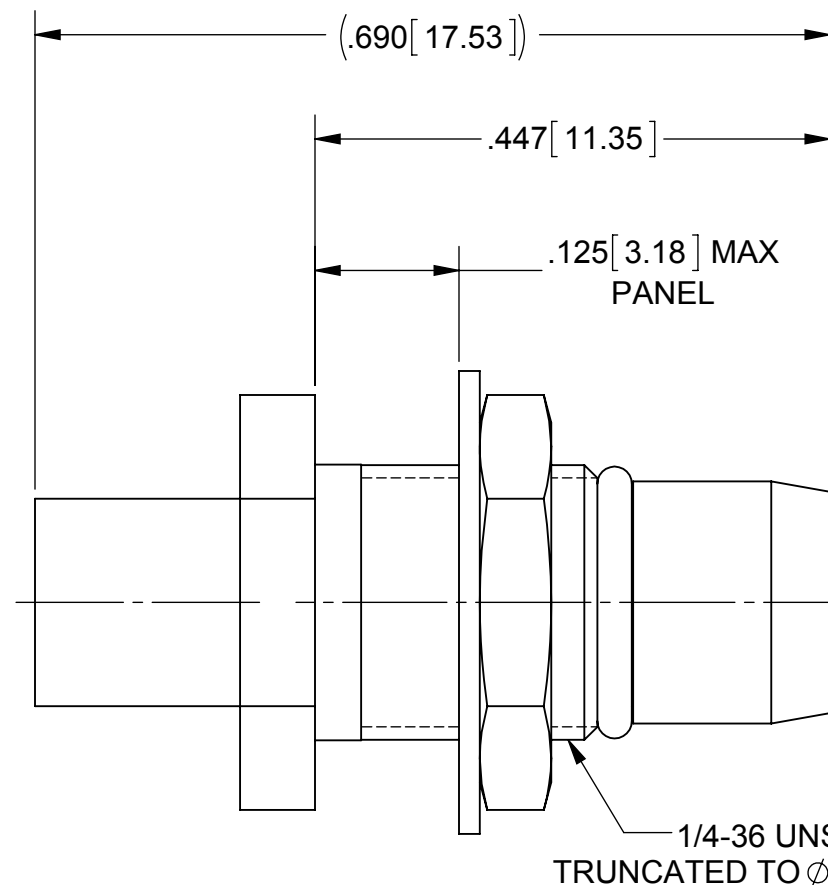
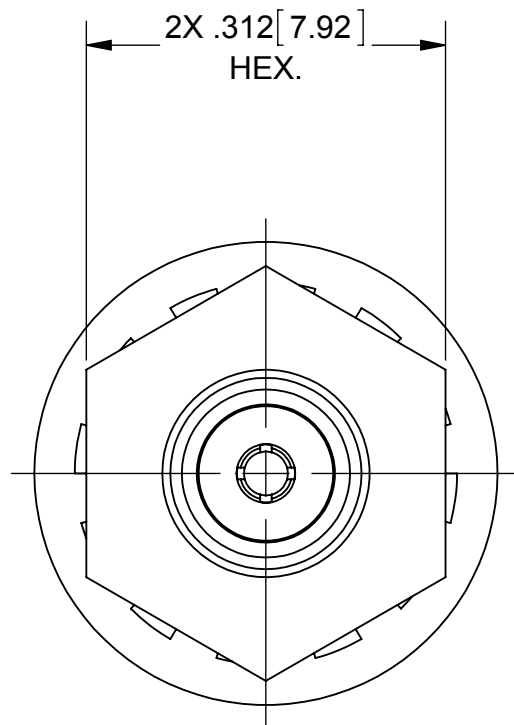

MATERIAL:

- BODY & HEX NUT: STAINLESS STEEL PER AMS-5640, ALLOY UNS S30300, TYPE 1
- CONTACT: BERYLLIUM COPPER PER ASTM B196,
- GASKET: FLUORCARBON RUBBER PER MIL-R-832488 TYPE 1, CLASS 1.
- INSULATOR: PTFE PER ASTM D1710, TYPE I, GRADE 1, CLASS B
- LOCK WASHER: STAINLESS STEEL

FINISH:

- BODY & CONTACT: GOLD PER ASTM B488, TYPE II, CODE C, CLASS .76, OVER NICKEL PER AMS-QQ-N-290, CLASS 1, .00005" MIN.

- HEX NUT & LOCK WASHER: PASSIVATED PER AMS-2700

PERFORMANCE:

- IMPEDANCE: 50 OHMS
- FREQ. RANGE: DC TO 18.0 GHz

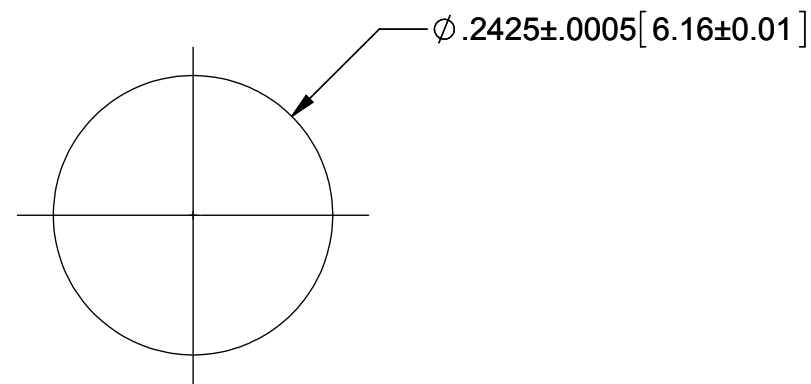

RECOMMENDED MOUNTING HOLE

MATERIAL: SEE NOTES	DIMENSIONS ARE IN INCHES TOLERANCES: FRACTIONAL: ±1/64 ANGULAR: X° ±1'0" X°X' ±15'	UNLESS OTHERWISE SPECIFIED 1) ALL DIMENSIONS ARE IN INCHES (MILLIMETERS) 2) ALL DIMENSIONS ARE AFTER PLATING. 3) BREAK CORNERS & EDGES .005 R. MAX. 4) CHAM. 1ST & LAST THREADS. 5) SURFACE ROUGHNESS 63-MIL-STD-10. 6) DIA: 'S ON COMMON CENTERS TO BE CONCENTRIC WITHIN .005 T.I.R. 7) REMOVE ALL BURRS	 2400 Centrepark West Drive, Suite 100 West Palm Beach, FL 33409 TITLE: BMA PLUG JAM NUT MOUNT FOR .141 S.R. CABLE
FINISH: SEE NOTES	DECIMAL: .X ±.030 .XX ±.010 .XXX ±.005	INTERPRET DIMENSIONS AND TOLERANCES PER ASME Y14.5M - 1994	
SURFACE AREA: N/A	THIRD ANGLE PROJECTION	DRAWN: MEB 10/15/02	SIZE CAGE CODE DWG. NO. B 95077 1709-6002
PROPRIETARY THE INFORMATION CONTAINED IN THIS DRAWING IS THE SOLE PROPERTY OF SV MICROWAVE, INC. ANY REPRODUCTION IN PART OR AS A WHOLE WITHOUT THE WRITTEN PERMISSION OF SV MICROWAVE, INC IS PROHIBITED.		CHECKED: STW 10/15/02	SCALE: 6:1
		APPROVED: STW 10/15/02	SHEET 1 OF 1