

# PRODUCT DATA DRAWING

REVISION HISTORY			
REV	DESCRIPTION	DATE	APPROVED
-	REL. DCN 35417	10/07	STW

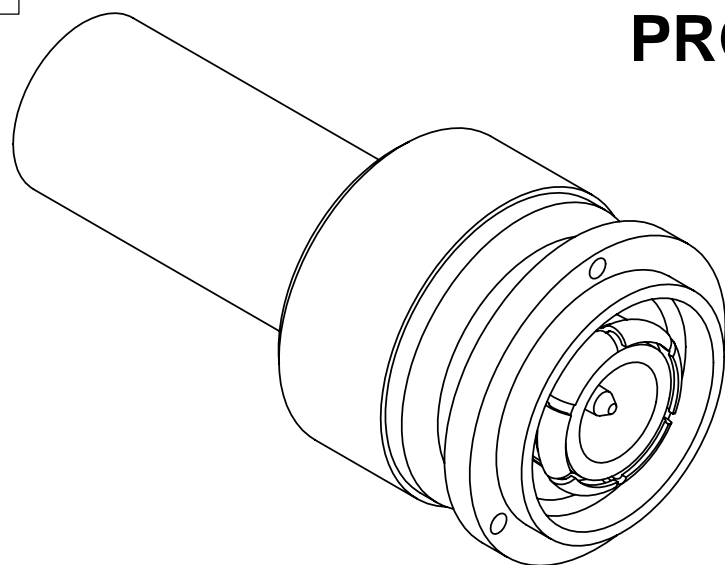

**MATERIAL:**

BODY, CONTACT & COUPLING NUT: BRASS PER ASTM B16, ALLOY UNS No. C36000

OUTER CONTACT: BERYLLIUM COPPER PER ASTM B194, ALLOY No. UNS C17200

LOCK RING: PHOSPHOR BRONZE PER ASTM B159 ALLOY 51000

INSULATOR: PTFE PER ASTM D1710, TYPE I, GRADE 1, CLASS B

GASKET: SILICONE RUBBER PER A-A-59588, CLASS 2B, GRADE 50/60

CRIMP SLEEVE: COPPER PER ASTM B301 ALLOY UNS C18700, H04

SHRINK TUBING: SCL POLYOLEFIN PER MIL-DTL-23053/4-104-0

**FINISH:**

BODY, OUTER CONTACT, COUPLING NUT & CRIMP SLEEVE: SILVER PER QQ-S-365 TYPE II, GRADE A, .00020" MIN.

CONTACT: GOLD PER ASTM B488, TYPE II, CODE C, CLASS 1.27; OVER NICKEL PER AMS-QQ-N-290, CLASS 1, .00005" MIN.

**PERFORMANCE:**

IMPEDANCE: 50 OHMS  
 FREQ. RANGE: DC TO 11.0 GHZ  
 VSWR: 1.30:1 DC TO 11.0 GHZ (OR APPROX. 80% OF THE CABLE CUTOFF FREQUENCY)

INSERTION LOSS: .06 X SQRT(F(F IN GHZ))

DWV: 1500 VRMS

OPERATING TEMP.: -65°C TO +165°C

ENGAGEMENT/

DISENGAGEMENT: 2 IN-LBS

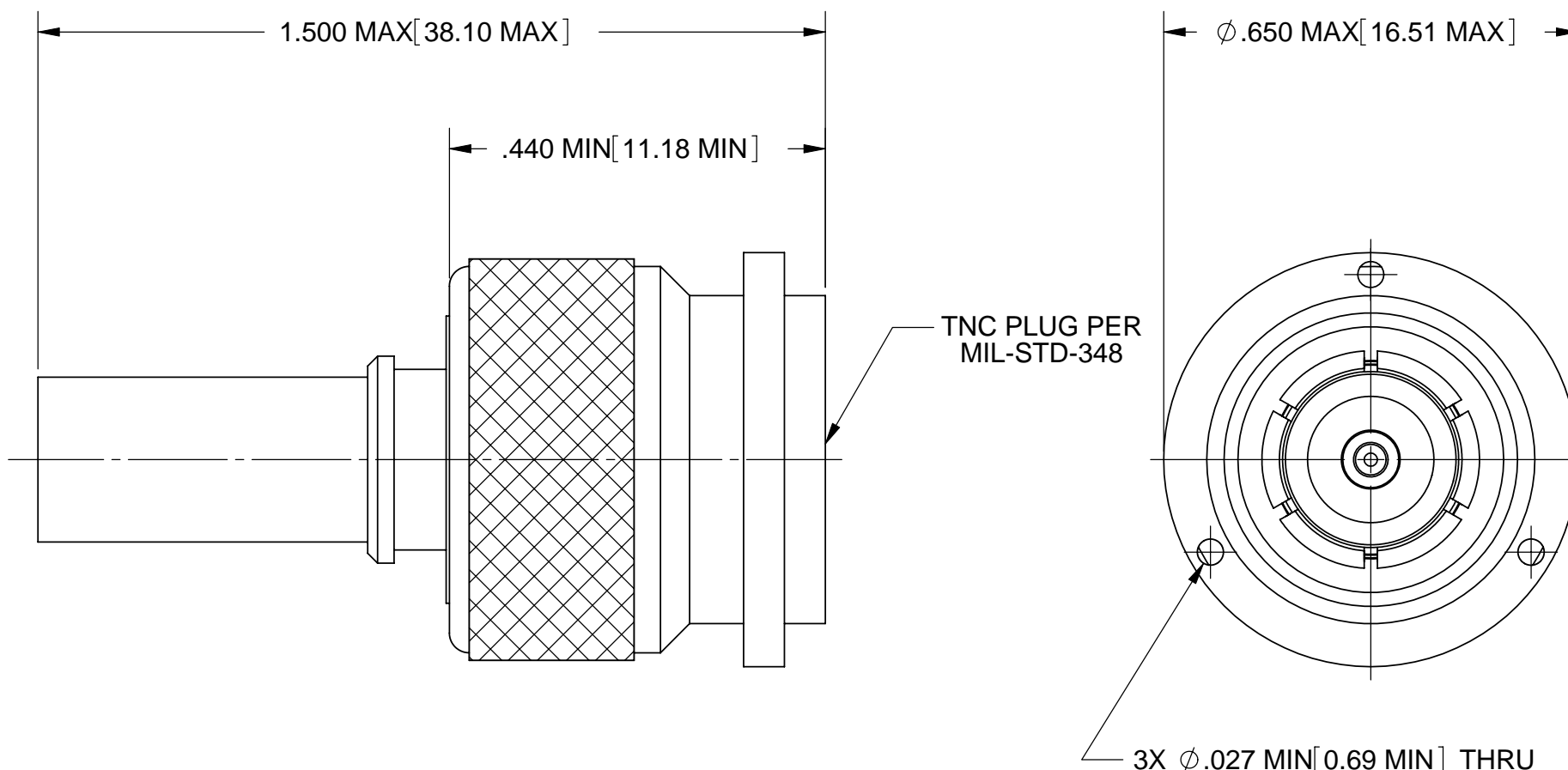

**NOTES:**

- HEAT SHRINK TUBING NOT SHOWN.

MATERIAL: SEE NOTES	DIMENSIONS ARE IN INCHES TOLERANCES: FRACTIONAL: ±1/64 ANGULAR: X° ±1'0" X"X' ±15'	UNLESS OTHERWISE SPECIFIED 1) ALL DIMENSIONS ARE IN INCHES (MILLIMETERS) 2) ALL DIMENSIONS ARE AFTER PLATING. 3) BREAK CORNERS & EDGES .005 R. MAX. 4) CHAM. 1ST & LAST THREADS. 5) SURFACE ROUGHNESS 63-MIL-STD-10. 6) DIA.'S ON COMMON CENTERS TO BE CONCENTRIC WITHIN .005 T.I.R. 7) REMOVE ALL BURRS	<b>SV Microwave, Inc.</b> 2400 Centrepark West Drive, Suite 100 West Palm Beach, FL 33409
FINISH: SEE NOTES	DECIMAL: .X ±.030 .XX ±.010 .XXX ±.005	INTERPRET DIMENSIONS AND TOLERANCES PER ASME Y14.5M - 1994	TITLE: TNC PLUG CRIMP FOR RG-303 CABLE
SURFACE AREA: N/A	THIRD ANGLE PROJECTION	DRAWN: ADK 10/02/07	SIZE: B CAGE CODE: 95077 DWG. NO.: M39012/26B0015
PROPRIETARY THE INFORMATION CONTAINED IN THIS DRAWING IS THE SOLE PROPERTY OF SV MICROWAVE, INC. ANY REPRODUCTION IN PART OR AS A WHOLE WITHOUT THE WRITTEN PERMISSION OF SV MICROWAVE, INC IS PROHIBITED.		CHECKED: STW 10/03/07	SCALE: 4:1 SHEET 1 OF 1
		APPROVED: STW 10/03/07	