

PRODUCT DATA DRAWING

REVISION HISTORY			
REV	DESCRIPTION	DATE	APPROVED
B	REV. DCN 47945	09/17/18	STW

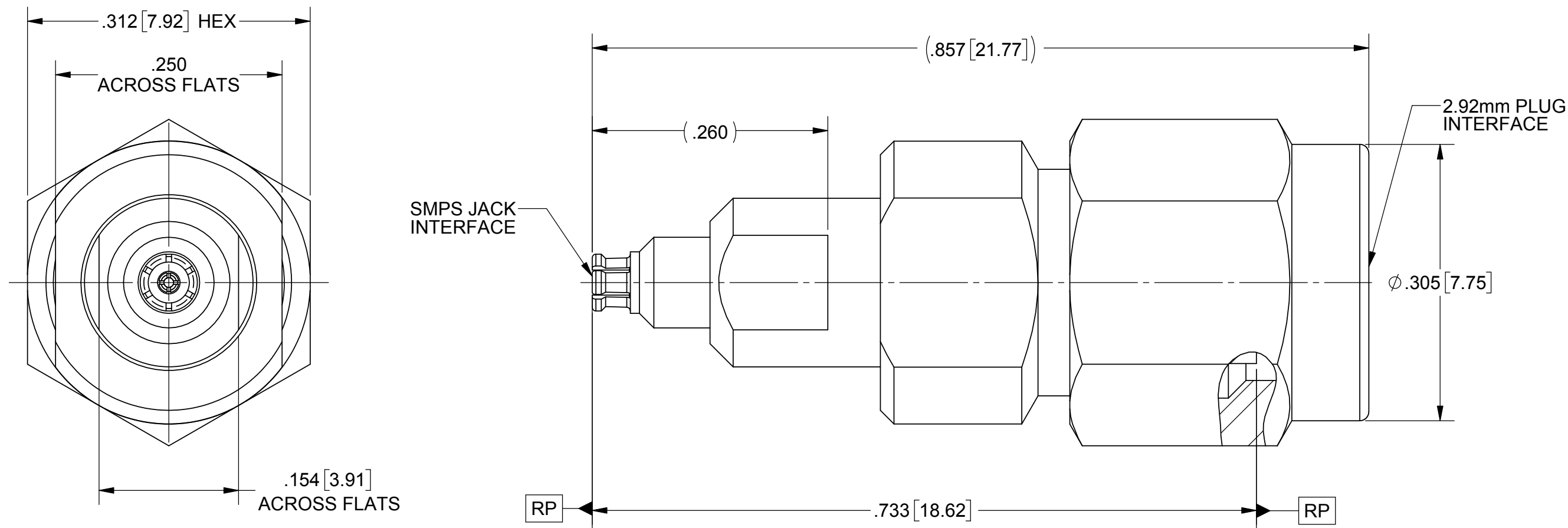

MATERIAL:

2.92mm BODY & COUPLING NUT: STAINLESS STEEL PER AMS-5640, ALLOY UNS S30300, TYPE 1 OR ASTM A582, TYPE 303, CONDITION A.

LOCK RING: BERYLLIUM COPPER PER ASTM B194, B196 OR B197 ALLOY No. UNS C17200 OR C17300.

CONTACT & SMPS BODY: BERYLLIUM COPPER PER ASTM B196, ALLOY No. UNS C17300, TD04.

INSULATOR: PTFE PER ASTM D1710, TYPE I, GRADE 1, CLASS B

BEAD: PEI (ULTEM 10000 PER ASTM D5205.

FINISH:

2.92mm BODY & COUPLING NUT: PASSIVATED PER AMS-2700.

CONTACT & SMPS BODY: GOLD PER ASTM B488, TYPE II, CODE C, CLASS 1.27 OVER NICKEL PER AMS-QQ-N-290, CLASS 1, .00005" MIN.

PERFORMANCE:

IMPEDANCE: 50 OHMS
FREQ. RANGE: DC TO 40.0 GHz

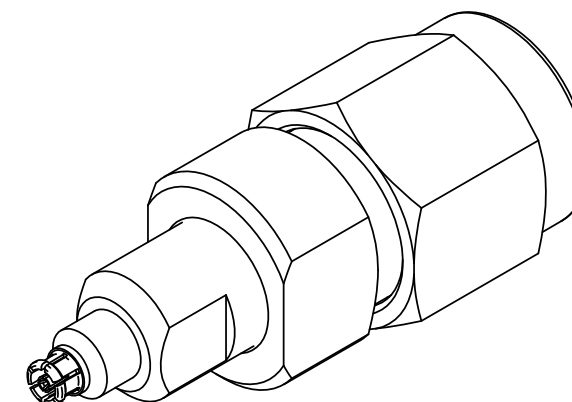

MATERIAL: SEE NOTES	DIMENSIONS ARE IN INCHES TOLERANCES: FRACTIONAL: ±1/64 ANGULAR: X° ±1'0" X"X' ±15'	UNLESS OTHERWISE SPECIFIED 1) ALL DIMENSIONS ARE IN INCHES (MILLIMETERS) 2) ALL DIMENSIONS ARE AFTER PLATING. 3) BREAK CORNERS & EDGES .005 R. MAX. 4) CHAM. 1ST & LAST THREADS. 5) SURFACE ROUGHNESS 63-MIL-STD-10. 6) DIA. 'S ON COMMON CENTERS TO BE CONCENTRIC WITHIN .005 T.I.R. 7) REMOVE ALL BURRS	 Amphenol 2400 Centrepark West Drive, Suite 100 West Palm Beach, FL 33409 TITLE: 2.92mm MALE TO SMPS FEMALE ADAPTER
FINISH: SEE NOTES	DECIMAL: X ±.030 .XX ±.010 .XXX ±.005	INTERPRET DIMENSIONS AND TOLERANCES PER ASME Y14.5M - 1994	
SURFACE AREA: N/A	THIRD ANGLE PROJECTION	DRAWN: VB 13/03/17	SIZE: B CAGE CODE: 95077 DWG. NO.: SF1115-6091
PROPRIETARY THE INFORMATION CONTAINED IN THIS DRAWING IS THE SOLE PROPERTY OF SV MICROWAVE, INC. ANY REPRODUCTION IN PART OR AS A WHOLE WITHOUT THE WRITTEN PERMISSION OF SV MICROWAVE, INC IS PROHIBITED.		CHECKED: MAL 13/03/17	SCALE: 4:1
		APPROVED: MAL 13/03/17	SHEET 1 OF 1