

PRODUCT DATA DRAWING

REVISION HISTORY			
REV	DESCRIPTION	DATE	APPROVED
-	DCN 37491	04/10	STW
A	DCN 37714	08/10	DAL
B	DCN 46687	7/17	STW

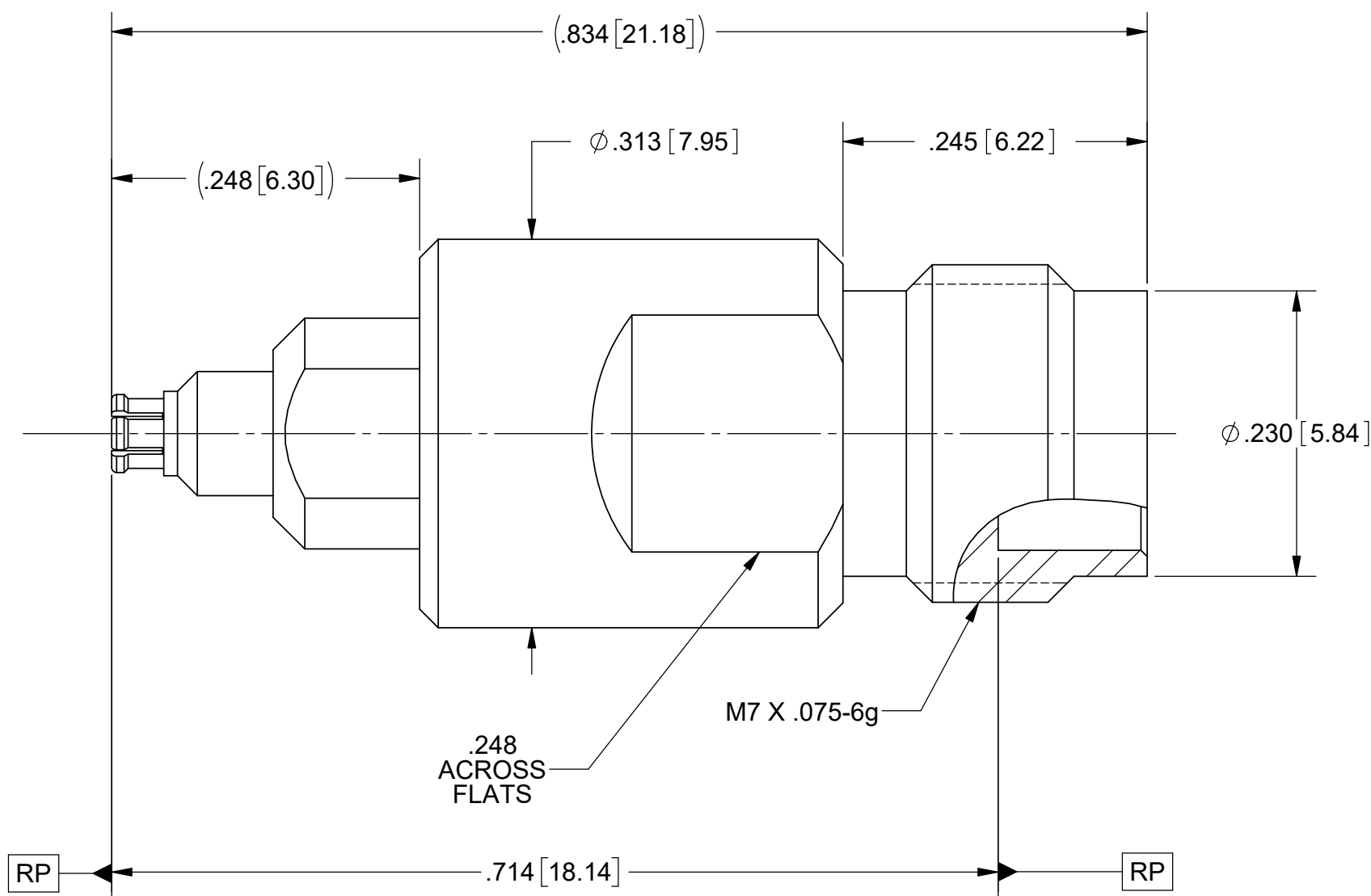
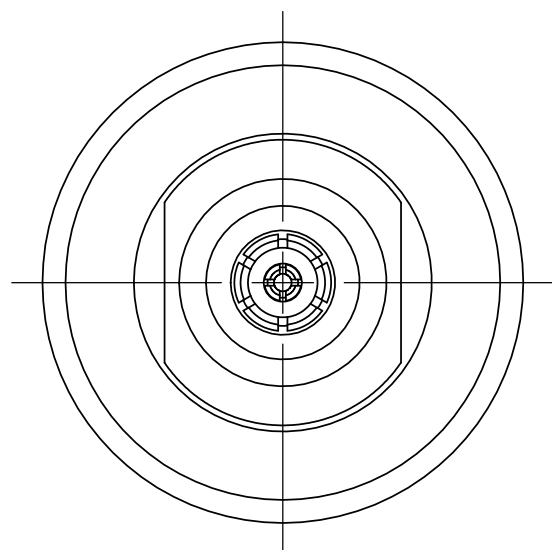

MATERIAL:

2.4 mm BODY: STAINLESS STEEL PER AMS-5640, ALLOY UNS S30300, TYPE 1

CONTACT & SMPS BODY: BERYLLIUM COPPER PER ASTM B196, ALLOY No. UNS C17300, TD04

INSULATOR: PTFE PER ASTM D1710, TYPE I, GRADE 1, CLASS B

BEAD: ULTEM 1000

FINISH:

2.4 mm BODY: PASSIVATED PER AMS-2700

CONTACT & SMPS BODY: GOLD PER ASTM B488, TYPE II, CODE C, CLASS 1.27; OVER NICKEL PER AMS-QQ-N-290, CLASS 1, .00005" MIN.

PERFORMANCE:

IMPEDANCE: 50 OHMS
 FREQ. RANGE: DC TO 50.0 GHz
 VSWR: 1.20:1 MAX. DC TO 26.5 GHz
 1.30:1 MAX. 26.5 TO 50.0 GHz

MATERIAL: SEE NOTES	DIMENSIONS ARE IN INCHES TOLERANCES: FRACTIONAL: ±1/64 ANGULAR: X° ±1'0" X'X' ±15'	UNLESS OTHERWISE SPECIFIED 1) ALL DIMENSIONS ARE IN INCHES (MILLIMETERS) 2) ALL DIMENSIONS ARE AFTER PLATING. 3) BREAK CORNERS & EDGES .005 R. MAX. 4) CHAM. 1ST & LAST THREADS. 5) SURFACE ROUGHNESS 63-MIL-STD-10. 6) DIA.'S ON COMMON CENTERS TO BE CONCENTRIC WITHIN .005 T.I.R. 7) REMOVE ALL BURRS	SV Microwave, Inc. 2400 Centrepark West Drive, Suite 100 West Palm Beach, FL 33409
FINISH: SEE NOTES	DECIMAL: X ±.030 .XX ±.010 .XXX ±.005	INTERPRET DIMENSIONS AND TOLERANCES PER ASME Y14.5M - 1994	TITLE: SMPS MALE FD TO 2.4mm FEMALE ADAPTER
SURFACE AREA: N/A	THIRD ANGLE PROJECTION	DRAWN: FED 04/20/10 CHECKED: STW 04/20/10 APPROVED: STW 04/20/10	SIZE: B CAGE CODE: 95077 DWG. NO.: SF1116-6022
PROPRIETARY THE INFORMATION CONTAINED IN THIS DRAWING IS THE SOLE PROPERTY OF SV MICROWAVE, INC. ANY REPRODUCTION IN PART OR AS A WHOLE WITHOUT THE WRITTEN PERMISSION OF SV MICROWAVE, INC IS PROHIBITED.			SCALE: 8:1 SHEET 1 OF 1