

# PRODUCT DATA DRAWING

REVISION HISTORY			
REV	DESCRIPTION	DATE	APPROVED
-	DCN 39326	08/12	STW
A	REV. DCN 41463	07/10/15	JMC
B	REV. DCN 48550	04/03/19	STW

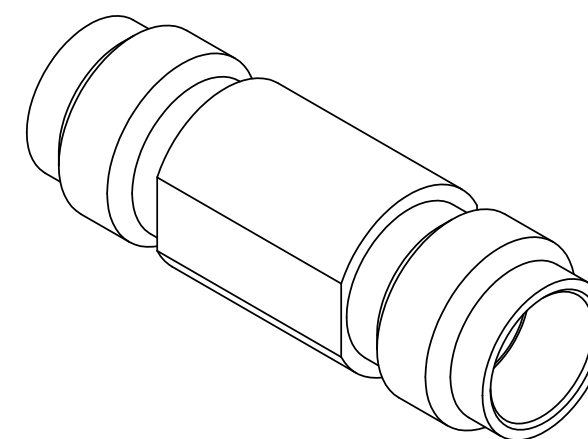
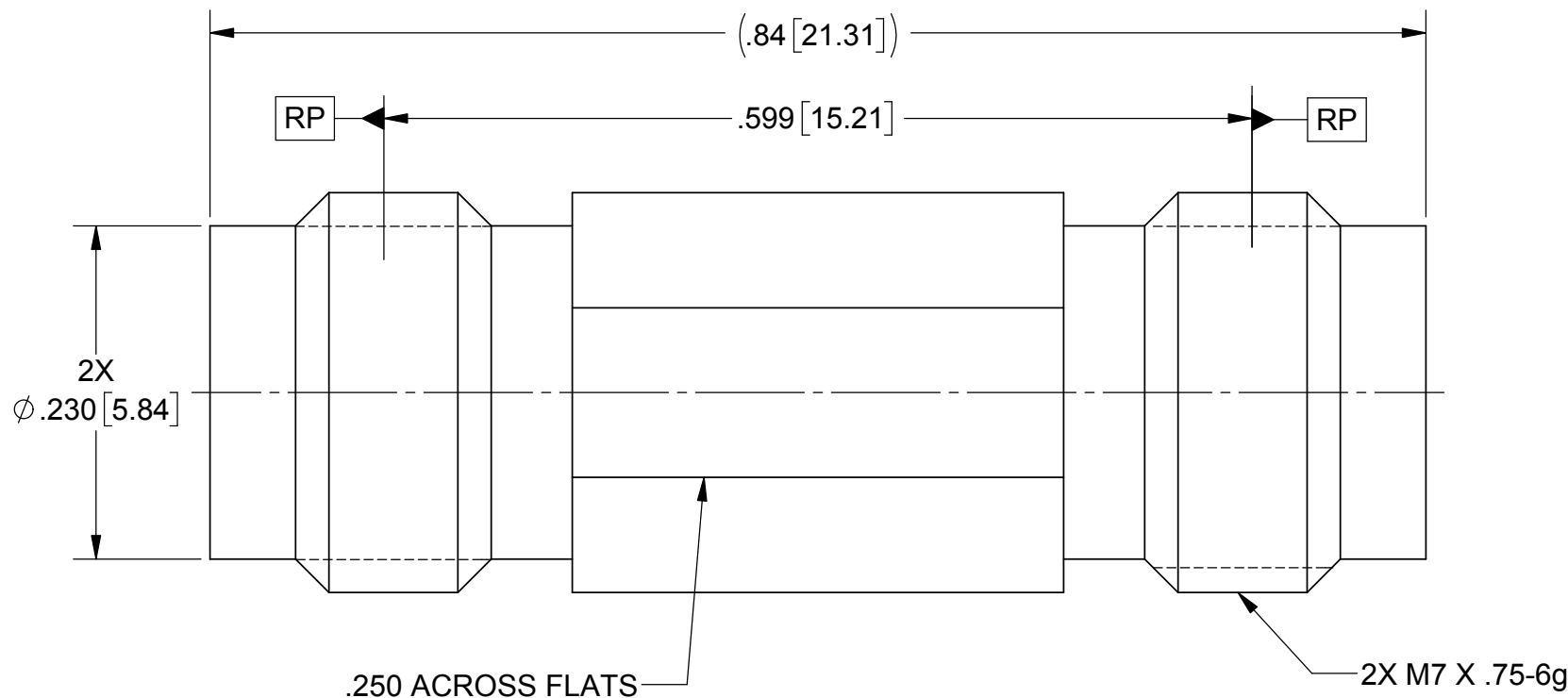
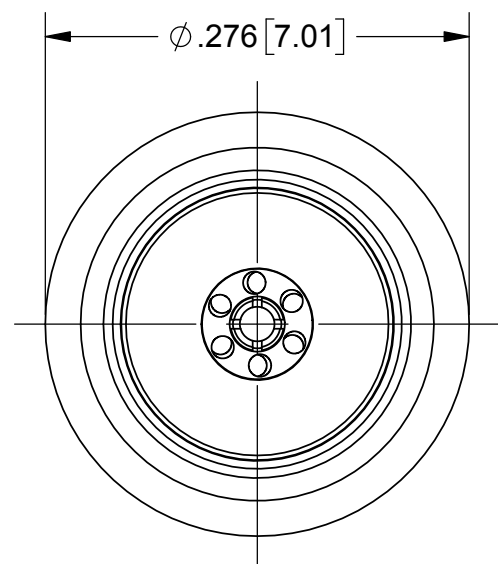

**MATERIAL:**

**BODY & INSERTS:** STAINLESS STEEL PER AMS-5640, ALLOY UNS S30300, TYPE 1 OR ASTM A582, TYPE 303, CONDITION A.

**CONTACT:** BERYLLIUM COPPER PER ASTM B196, ALLOY No. UNS C17300, TD04.

**DIELECTRICS:** PEI (ULTEM 1000) PER ASTM D5205.

**FINISH:**

**BODY & INSERTS:** PASSIVATED PER AMS 2700.

**CONTACT:** GOLD PER ASTM B488, TYPE II, CODE C, CLASS 1.27 OVER NICKEL PER AMS-QQ-N-290, CLASS 1, .00005" MIN.

**PERFORMANCE:**

**FREQ. RANGE:** DC TO 65 GHz

**VSWR:** 1.30:1 DC TO 65 GHz

MATERIAL: SEE NOTES	DIMENSIONS ARE IN INCHES TOLERANCES: FRACTIONAL: ±1/64 ANGULAR: X° ±1'0" X'X' ±15'	UNLESS OTHERWISE SPECIFIED 1) ALL DIMENSIONS ARE IN INCHES (MILLIMETERS) 2) ALL DIMENSIONS ARE AFTER PLATING. 3) BREAK CORNERS & EDGES .005 R. MAX. 4) CHAM. 1ST & LAST THREADS. 5) SURFACE ROUGHNESS 63-MIL-STD-10. 6) DIA. 'S ON COMMON CENTERS TO BE CONCENTRIC WITHIN .005 T.I.R. 7) REMOVE ALL BURRS	<b>SV Microwave, Inc.</b> 2400 Centrepark West Drive, Suite 100 West Palm Beach, FL 33409
FINISH: SEE NOTES	DECIMAL: X ±.030 .XX ±.010 .XXX ±.005	INTERPRET DIMENSIONS AND TOLERANCES PER ASME Y14.5M - 1994	TITLE: <b>1.85 mm FEMALE TO FEMALE ADAPTER</b>
SURFACE AREA: N/A	THIRD ANGLE PROJECTION	DRAWN: FSG 08/28/12	SIZE: <b>B</b> CAGE CODE: <b>95077</b> DWG. NO.: <b>SF1133-6008</b>
PROPRIETARY THE INFORMATION CONTAINED IN THIS DRAWING IS THE SOLE PROPERTY OF SV MICROWAVE, INC. ANY REPRODUCTION IN PART OR AS A WHOLE WITHOUT THE WRITTEN PERMISSION OF SV MICROWAVE, INC IS PROHIBITED.		CHECKED: STW 08/28/12 APPROVED: STW 08/28/12	SCALE: 8:1 SHEET 1 OF 1