

PRODUCT DATA DRAWING

REVISION HISTORY			
REV	DESCRIPTION	DATE	APPROVED
A	DCN 41727	10/15	DAL
B	DCN 48428	02/19	STW

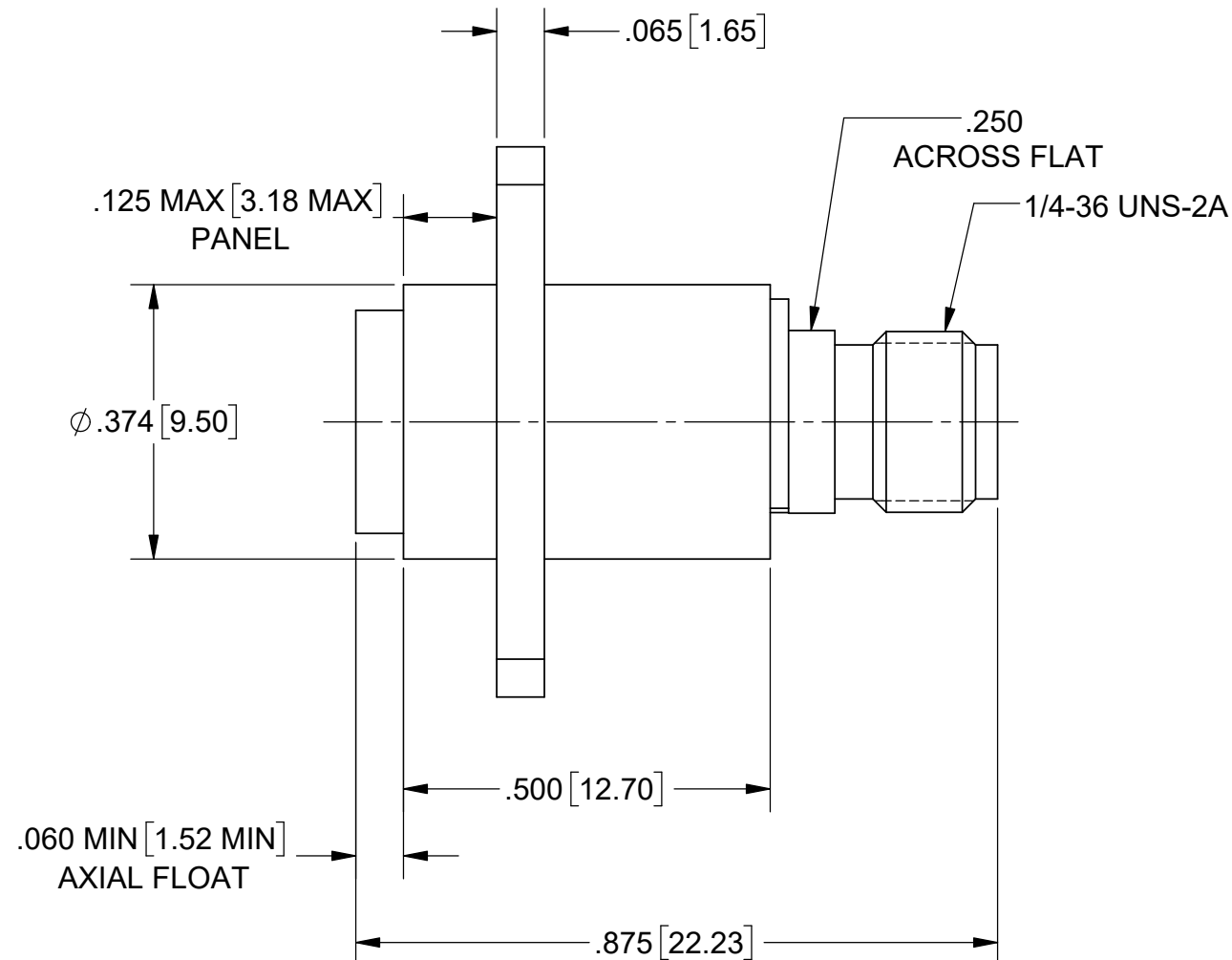
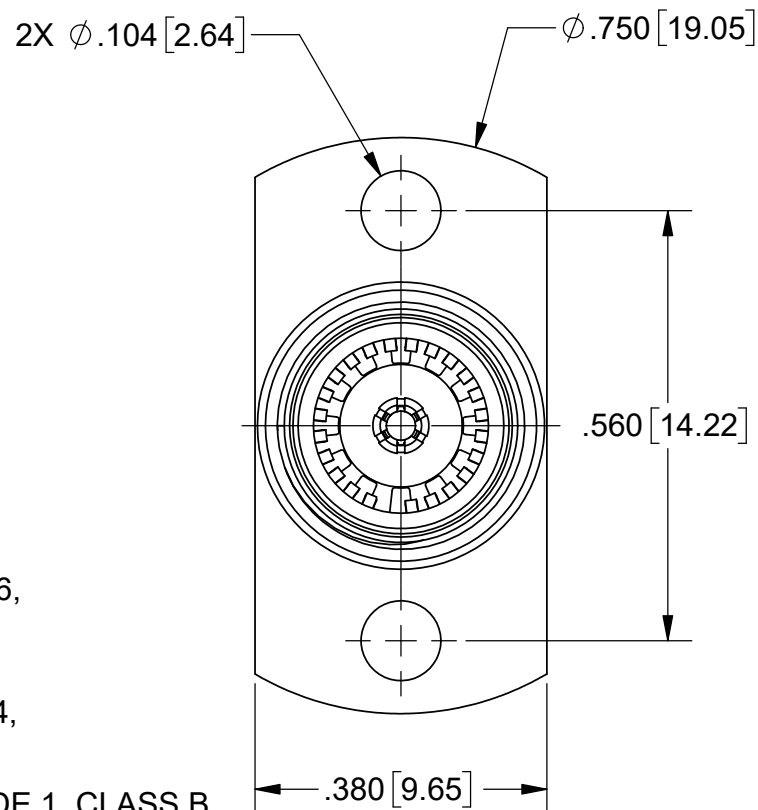
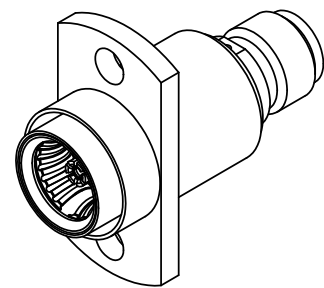

MATERIAL:

- BODIES & BUSHING:** STAINLESS STEEL PER AMS-5640, ALLOY UNS S30300, TYPE 1
- CONTACT SLEEVE & CONTACT:** BERYLLIUM COPPER PER ASTM B196, ALLOY No. UNS C17300, TD04
- SHIM SPRING & OUTER CONTACT:** BERYLLIUM COPPER PER ASTM B194, ALLOY No. UNS C17200, TD04
- INSULATOR:** PTFE PER ASTM D1710, TYPE I, GRADE 1, CLASS B
- E-RING:** STAINLESS STEEL TYPE PH 15-7 OR 17-7
- COMPRESSION SPRING:** 302 STAINLESS STEEL
- FINISH:**
- BODY, BUSHING, COMPRESSION SPRING, E-RING, & OUTER BODY:** PASSIVATED PER AMS-2700
- CONTACT, CONTACT SLEEVE, SHIM SPRING & OUTER CONTACT:** GOLD PER ASTM B 488, TYPE II, CODE C, CLASS .76, OVER NICKEL PER AMS-QQ-N-290, CLASS 1, .00010" MIN.

PERFORMANCE:

- IMPEDANCE:** 50 OHMS
- FREQ. RANGE:** DC TO 22.0 GHz

MATERIAL: SEE NOTES	DIMENSIONS ARE IN INCHES TOLERANCES: FRACTIONAL: ±1/64 ANGULAR: X° ±1'0" X'X' ±15'	UNLESS OTHERWISE SPECIFIED 1) ALL DIMENSIONS ARE IN INCHES (MILLIMETERS) 2) ALL DIMENSIONS ARE AFTER PLATING. 3) BREAK CORNERS & EDGES .005 R. MAX. 4) CHAM. 1ST & LAST THREADS. 5) SURFACE ROUGHNESS 63-MIL-STD-10. 6) DIA.'S ON COMMON CENTERS TO BE CONCENTRIC WITHIN .005 T.I.R. 7) REMOVE ALL BURRS	 2400 Centrepark West Drive, Suite 100 West Palm Beach, FL 33409 TITLE: SMA JACK TO BMA JACK, FLOATING FLANGE MOUNT ADAPTER
FINISH: SEE NOTES	DECIMAL: X ±.030 .XX ±.010 .XXX ±.005	INTERPRET DIMENSIONS AND TOLERANCES PER ASME Y14.5M - 1994	
SURFACE AREA: N/A	THIRD ANGLE PROJECTION	DRAWN: VMJ 07/24/01	SIZE: B CAGE CODE: 95077 DWG. NO. SF1157-6009
PROPRIETARY THE INFORMATION CONTAINED IN THIS DRAWING IS THE SOLE PROPERTY OF SV MICROWAVE, INC. ANY REPRODUCTION IN PART OR AS A WHOLE WITHOUT THE WRITTEN PERMISSION OF SV MICROWAVE, INC IS PROHIBITED.		CHECKED: STW 07/25/01	SCALE: 4:1 SHEET 1 OF 1
		APPROVED: STW 07/25/01	