

# PRODUCT DATA DRAWING

REVISION HISTORY			
REV	DESCRIPTION	DATE	APPROVED
A	DCN 42960	12/16	STW

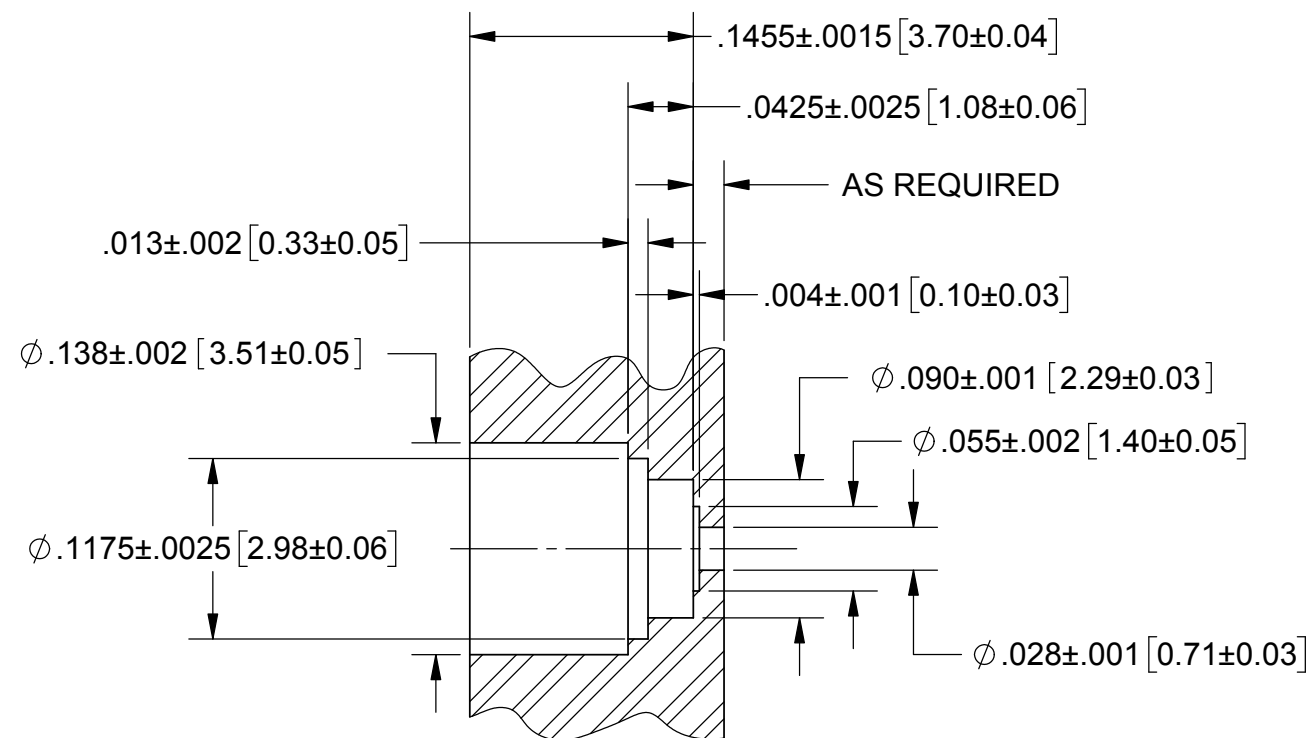

RECOMMENDED MOUNTING HOLE

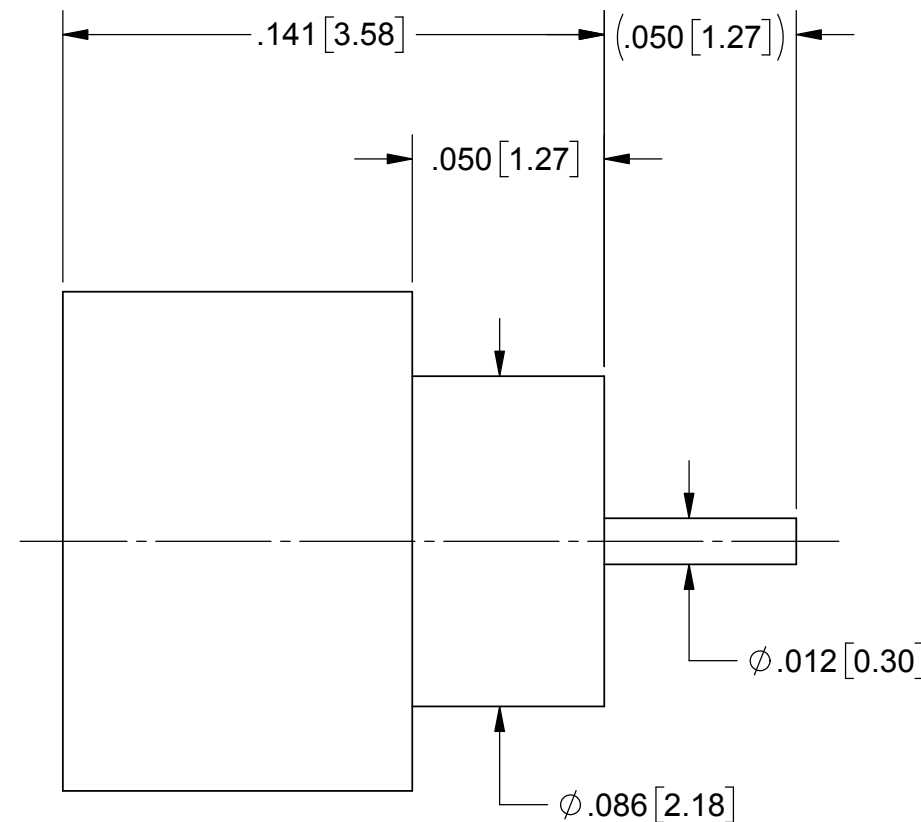
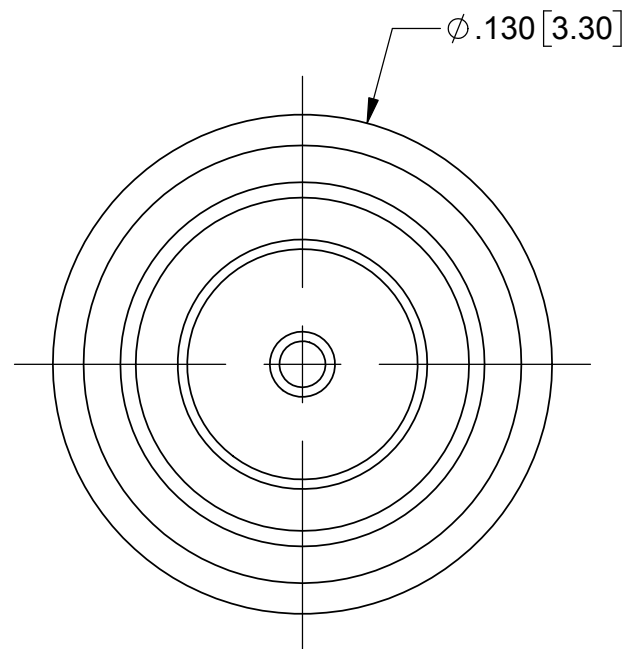

**MATERIAL:**

BODY & PIN: KOVAR PER ASTM-F 15-61P  
 GLASS: CORNING #7070 OR EQUIVALENT

**FINISH:**

BODY & PIN: GOLD PER ASTM B488, TYPE II, CODE C, CLASS 1.27, OVER NICKEL PER AMS-QQ-N-290, CLASS 1, .00005" MIN.

**PERFORMANCE:**

IMPEDANCE: 50 OHMS  
 FREQ. RANGE: DC TO 40.0 GHz  
 VSWR: 1.25:1 DC TO 26.5 GHz  
 1.35:1 26.5 TO 40.0 GHz  
 INSERTION LOSS: .12 X SQRT(F(F IN GHz))  
 DWV: 325 VRMS  
 OPERATING TEMP.: -55 °C TO +165 °C

MATERIAL: SEE NOTES	DIMENSIONS ARE IN INCHES TOLERANCES: FRACTIONAL: ±1/64 ANGULAR: X° ±1'0" X°X' ±15'	UNLESS OTHERWISE SPECIFIED 1) ALL DIMENSIONS ARE IN INCHES (MILLIMETERS) 2) ALL DIMENSIONS ARE AFTER PLATING. 3) BREAK CORNERS & EDGES .005 R. MAX. 4) CHAM. 1ST & LAST THREADS. 5) SURFACE ROUGHNESS 63-MIL-STD-10. 6) DIA.'S ON COMMON CENTERS TO BE CONCENTRIC WITHIN T.I.R. 7) REMOVE ALL BURRS	<b>SV Microwave, Inc.</b> 2400 Centrepark West Drive, Suite 100 West Palm Beach, FL 33409
FINISH: SEE NOTES	DECIMAL: X ±.030 .XX ±.010 .XXX ±.005	INTERPRET DIMENSIONS AND TOLERANCES PER ASME Y14.5M - 1994	TITLE: <b>SMPM SB MALE HERMETIC SHROUD</b>
SURFACE AREA: N/A	THIRD ANGLE PROJECTION	DRAWN: FED 02/28/11 CHECKED: STW 02/28/11 APPROVED: STW 02/28/11	SIZE: <b>B</b> CAGE CODE: <b>95077</b> DWG. NO.: <b>3211-60028</b>
<p><b>PROPRIETARY</b></p> <p>THE INFORMATION CONTAINED IN THIS DRAWING IS THE SOLE PROPERTY OF SV MICROWAVE, INC. ANY REPRODUCTION IN PART OR AS A WHOLE WITHOUT THE WRITTEN PERMISSION OF SV MICROWAVE, INC IS PROHIBITED.</p>		SCALE: 20:1	SHEET 1 OF 1