

PRODUCT DATA DRAWING

REVISION HISTORY			
REV	DESCRIPTION	DATE	APPROVED
-	DCN 47174	02/18	GPF

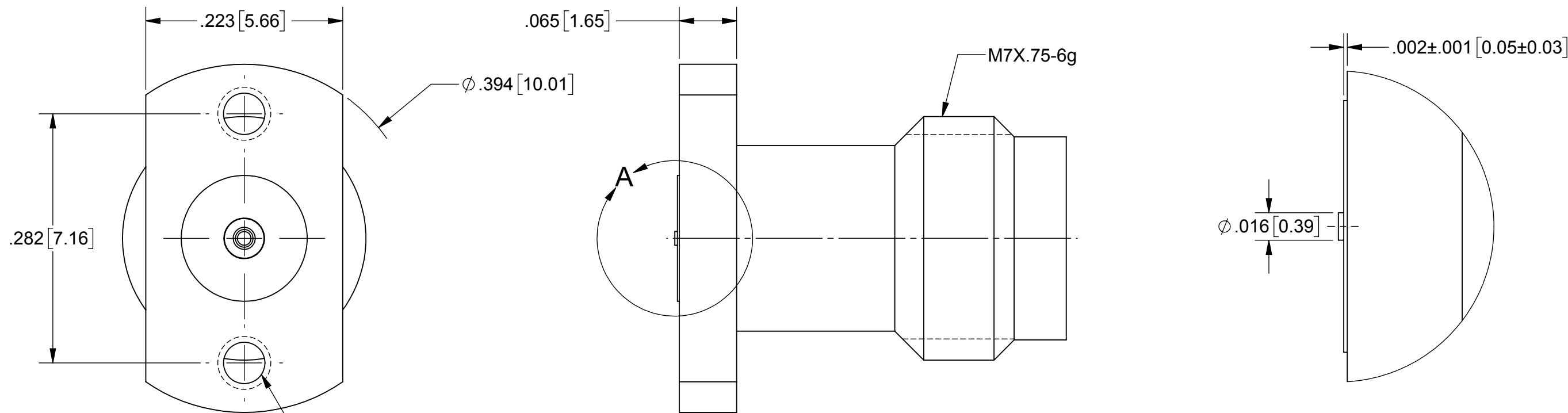

2X 0-80 UNF-2B THRU HOLES

DETAIL A
SCALE 16 : 1

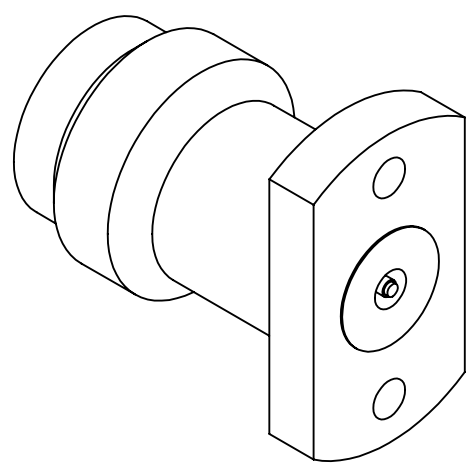

MATERIAL:

BODY & INSERT: STAINLESS STEEL PER AMS-5640, ALLOY UNS S30300, TYPE 1 AND ASTM A582, TYPE 303, CONDITION A.

CONTACT: BERYLLIUM COPPER PER ASTM B196, ALLOY No. UNS C17300, TD04

INSULATOR: PCTFE PER ASTM D1430

FINISH:

BODY & INSERT: PASSIVATED PER AMS-2700.

CONTACT: GOLD PER ASTM B488, TYPE II, CODE C, CLASS 1.27, OVER NICKEL PER AMS-QQ-N-290, CLASS 1, .00005" MIN.

PERFORMANCE:

IMPEDANCE: 50 OHMS
FREQ. RANGE: DC TO 67.0 GHz
VSWR: 1.35:1 DC TO 67.0 GHz
INSERTION LOSS: .05 X SQRT(F(F IN GHz))

NOTES:

- FOR A FOOTPRINT RECOMMENDATION SPECIFIC TO YOUR PCB, PLEASE CONTACT US AT applications@svmicro.com

SV P/N	DESCRIPTION	PCB THICKNESS	L
SF3321-60018-1S	INCL. TWO .188 SCREWS	.016 TO .123	.188
SF3321-60018-2S	INCL. TWO .250 SCREWS	.078 TO .185	.250
SF3321-60018	NO SCREWS	.005 TO .373	N/A

MATERIAL: SEE NOTES	DIMENSIONS ARE IN INCHES TOLERANCES: FRACTIONAL: ±1/64 ANGULAR: X° ±1'0" X°X' ±15'	UNLESS OTHERWISE SPECIFIED 1) ALL DIMENSIONS ARE IN INCHES (MILLIMETERS) 2) ALL DIMENSIONS ARE AFTER PLATING. 3) BREAK CORNERS & EDGES .005 R. MAX. 4) CHAM. 1ST & LAST THREADS. 5) SURFACE ROUGHNESS 63 MIL-STD-10. 6) DIA.'S ON COMMON CENTERS TO BE CONCENTRIC WITHIN .005 T.I.R. 7) REMOVE ALL BURRS	SV Microwave, Inc. 2400 Centrepark West Drive, Suite 100 West Palm Beach, FL 33409 TITLE: 1.85MM JACK 2 HOLE FLANGE COMPRESSION MOUNT (67 GHz)
FINISH: SEE NOTES	DECIMAL: X ±.030 .XX ±.010 .XXX ±.005	INTERPRET DIMENSIONS AND TOLERANCES PER ASME Y14.5M - 1994	
SURFACE AREA: N/A	THIRD ANGLE PROJECTION	DRAWN: VB 02/07/18	SIZE CAGE CODE DWG. NO. B 95077 SF3321-60018-XS
PROPRIETARY THE INFORMATION CONTAINED IN THIS DRAWING IS THE SOLE PROPERTY OF SV MICROWAVE, INC. ANY REPRODUCTION IN PART OR AS A WHOLE WITHOUT THE WRITTEN PERMISSION OF SV MICROWAVE, INC IS PROHIBITED.		CHECKED: GPF 02/07/18	SCALE: 4:1
		APPROVED: GPF 02/07/18	SHEET 1 OF 1