

PRODUCT DATA DRAWING

REVISION HISTORY			
REV	DESCRIPTION	DATE	APPROVED
C	DCN 49528	12/19	STW

MATERIAL:

BODY & COUPLING NUT: STAINLESS STEEL PER AMS-5640, ALLOY UNS S30300, TYPE 1; OR ASTM A582 TYPE 303, COND. A

LOCK RING & CONTACT: BERYLLIUM COPPER PER ASTM B196, ALLOY No. UNS C17300, TD04

INSULATOR: PTFE PER ASTM D1710, TYPE I, GRADE 1, CLASS B

GASKET: SILICONE RUBBER PER A-A-59588, CLASS 2B, GRADE 60/70

RESISTOR ELEMENT: ALUMINA SUBSTRATE WITH NICHROME RESISTOR

FINISH:

BODY: GOLD PER ASTM B 488, TYPE I, CODE C, CLASS 1.27, OVER NICKEL PER AMS-QQ-N-290, CLASS 1, .00005" MIN.

COUPLING NUT: GOLD PER ASTM B 488, TYPE I, CODE C, CLASS .50, OVER NICKEL PER AMS-QQ-N-290, CLASS 1, .00005" MIN.

CONTACT: GOLD PER ASTM B488, TYPE II, CODE C, CLASS 1.52, OVER NICKEL PER AMS-QQ-N-290, CLASS 1, .00005" MIN.

PERFORMANCE:

IMPEDANCE: 49-51 OHMS

FREQ. RANGE: DC TO 18.0 GHz.

VSWR: 1.10:1 MAX. DC TO 18.0 GHz.

OPERATING TEMP.: -55 °C TO +125 °C

AVG. POWER: 1 WATT (POWER INPUT DERATED LINEARLY FROM 25 °C TO .5 WATTS AT 125 °C)

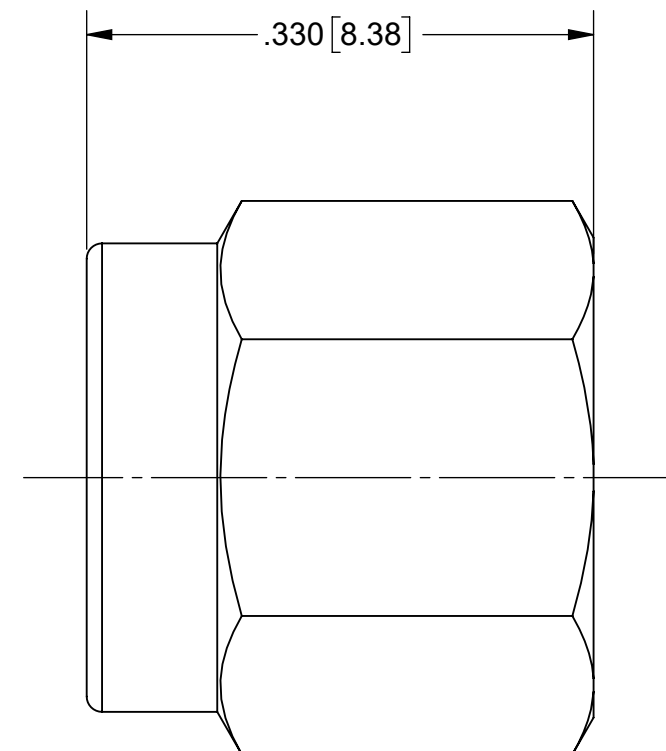
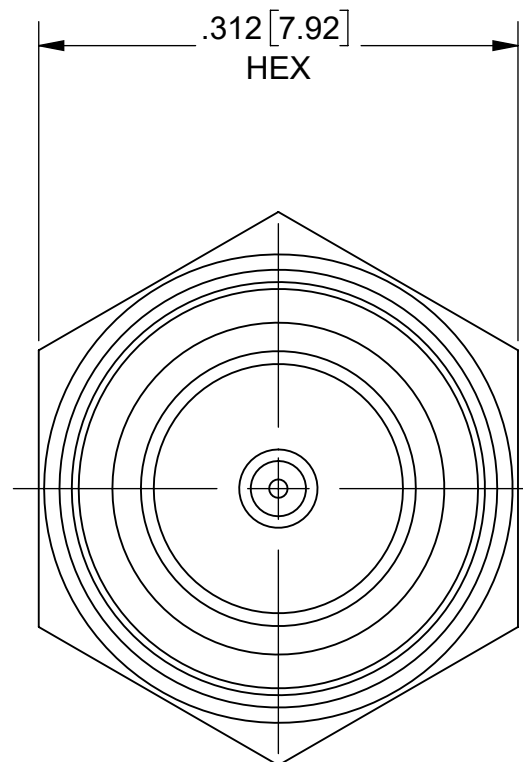

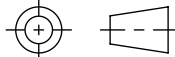
MATERIAL: SEE NOTES	DIMENSIONS ARE IN INCHES TOLERANCES: FRACTIONAL: ±1/64 ANGULAR: X° ±1°0' X'X' ±15'	UNLESS OTHERWISE SPECIFIED 1) ALL DIMENSIONS ARE IN INCHES (MILLIMETERS) 2) ALL DIMENSIONS ARE AFTER PLATING. 3) BREAK CORNERS & EDGES .005 R. MAX. 4) CHAM. 1ST & LAST THREADS. 5) SURFACE ROUGHNESS 63-MIL-STD-10. 6) DIA.'S ON COMMON CENTERS TO BE CONCENTRIC WITHIN .005 T.I.R. 7) REMOVE ALL BURRS	 www.svmicrowave.com TITLE: SMA 1 WATT PLUG TERMINATION
FINISH: SEE NOTES	DECIMAL: X ±.030 .XX ±.010 .XXX ±.005	INTERPRET DIMENSIONS AND TOLERANCES PER ASME Y14.5M - 1994	
SURFACE AREA: N/A	THIRD ANGLE PROJECTION	DRAWN: MGT 01/14/05	SIZE DWG. NO. B 8018-6061
PROPRIETARY THE INFORMATION CONTAINED IN THIS DRAWING IS THE SOLE PROPERTY OF SV MICROWAVE, INC. ANY REPRODUCTION IN PART OR AS A WHOLE WITHOUT THE WRITTEN PERMISSION OF SV MICROWAVE, INC IS PROHIBITED.		CHECKED: CCC 01/14/05	SCALE: 8:1
		APPROVED: CCC 01/14/05	SHEET 1 OF 1