

# PRODUCT DATA DRAWING

REVISION HISTORY			
REV	DESCRIPTION	DATE	APPROVED
-	DCN 38042	03/11	STW
A	DCN 49127	06/19	BNK

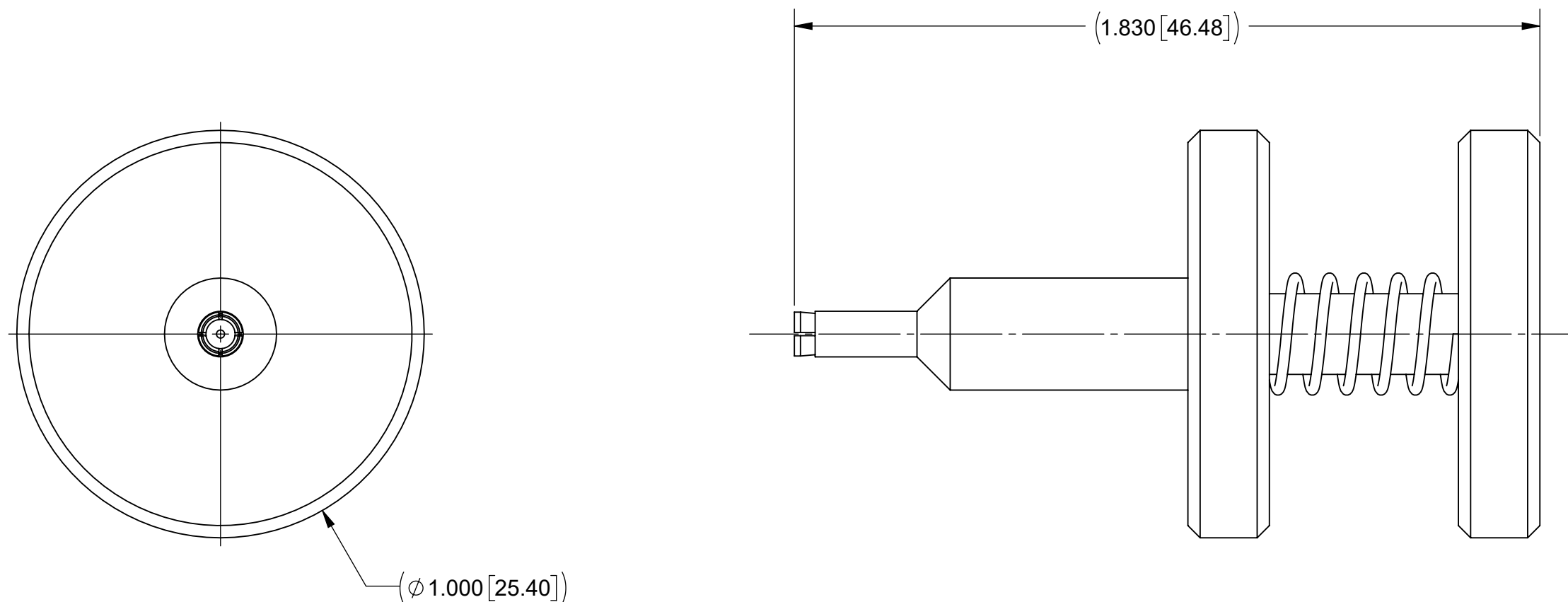

**MATERIAL:**

TUBE & SHAFT: STAINLESS STEEL PER AMS-5640,  
ALLOY UNS S30300, TYPE 1;  
OR ASTM A582 TYPE 303, COND. A

COLLET: BERYLLIUM COPPER PER ASTM B196,  
ALLOY No. UNS C17300, TD04

COMPRESSION SPRING: MUSIC WIRE

**FINISH:**

TUBE & SHAFT: PASSIVATED PER AMS-2700

COLLET: NICKEL PER AMS-QQ-N-290, CLASS 1,  
GRADE G

MATERIAL: SEE NOTES	DIMENSIONS ARE IN INCHES TOLERANCES: FRACTIONAL: ±1/64 ANGULAR: X° ±1'0" X'X' ±15'	UNLESS OTHERWISE SPECIFIED 1) ALL DIMENSIONS ARE IN INCHES (MILLIMETERS) 2) ALL DIMENSIONS ARE AFTER PLATING. 3) BREAK CORNERS & EDGES .005 R. MAX. 4) CHAM. 1ST & LAST THREADS. 5) SURFACE ROUGHNESS 63-MIL-STD-10. 6) DIA: 'S ON COMMON CENTERS TO BE CONCENTRIC WITHIN .005 T.I.R. 7) REMOVE ALL BURRS	<b>SV Microwave, Inc.</b> 2400 Centrepark West Drive, Suite 100 West Palm Beach, FL 33409
FINISH: SEE NOTES	DECIMAL: X ±.030 .XX ±.010 .XXX ±.005	INTERPRET DIMENSIONS AND TOLERANCES PER ASME Y14.5M - 1994	TITLE: <b>SMPM BULLET REMOVAL TOOL</b>
SURFACE AREA: N/A	THIRD ANGLE PROJECTION	DRAWN: FED 03/01/11	SIZE: <b>B</b> CAGE CODE: <b>95077</b> DWG. NO. <b>500-32-007</b>
<p><b>PROPRIETARY</b></p> <p>THE INFORMATION CONTAINED IN THIS DRAWING IS THE SOLE PROPERTY OF SV MICROWAVE, INC. ANY REPRODUCTION IN PART OR AS A WHOLE WITHOUT THE WRITTEN PERMISSION OF SV MICROWAVE, INC IS PROHIBITED.</p>		CHECKED: STW 03/01/11	SCALE: 3:1
		APPROVED: STW 03/01/11	SHEET 1 OF 1